

# APLISENS

MANUFACTURE OF PRESSURE TRANSMITTERS  
AND CONTROL INSTRUMENTS

## USER'S MANUAL

SMART PRESSURE TRANSMITTER

type: **APC-2000ALW**

SMART DIFFERENTIAL PRESSURE TRANSMITTER

type: **APR-2000ALW, APR-2200ALW, APR-2000GALW**  
**APR-2000ALW/L, APR-2200ALW/L**

SMART LEVEL PROBE





type: **APR-2000YALW**

SMART LEVEL TRANSMITTER **APC-2000ALW/L...**

Edition C3

WARSAW AUGUST 2016

Symbols used

Symbol	Description
	Warning to proceed strictly in accordance with the information contained in the documentation in order to ensure the safety and full functionality of the device.
	Information particularly useful during installation and operation of the device.
	Information particularly useful during installation and operation of an Ex device.
	Information on disposal of used equipment.

**BASIC REQUIREMENTS AND SAFE USE**



- **The manufacturer will not be liable for damage resulting from incorrect installation, failure to maintain the device in a suitably functional condition, or use of the device other than for its intended purpose.**
- Installation should be carried out by qualified personnel having the necessary authorisation to install electrical and pressure measuring devices. The installer is responsible for performing the installation in accordance with these instructions and with the electromagnetic compatibility and safety regulations and standards applicable to the type of installation.
- The device should be configured appropriately for the purpose for which it is to be used. Incorrect configuration may cause erroneous functioning, leading to damage to the device or an accident.
- In systems with pressure transmitters there exists, in case of leakage, a risk to personnel on the side where the medium is under pressure. All safety and protection requirements must be observed during installation, operation and inspections.
- If a device is not functioning correctly, disconnect it and send it for repair to the manufacturer or to a firm authorised by the manufacturer.



In order to minimise the risk of malfunction and associated risks to personnel, the device is not to be installed or used in particularly hostile conditions, where the following risks occur:

- possibility of mechanical impacts, excessive shocks and vibration;
- excessive temperature fluctuation;
- condensation of water vapour, dust, icing.



Installation of intrinsically safe versions should be performed with particular care, in accordance with the regulations and standards applicable to that type of installation.

Changes in the production of transmitters may precede a paper updating for the user. The current user manuals are available at <http://www.aplisens.pl>

## CONTENTS

<b>I.</b>	<b>APPENDIX Exd.ATEX</b> .....	<b>3</b>
<b>II.</b>	<b>APPENDIX Exd.IECEx</b> .....	<b>7</b>
<b>III.</b>	<b>APPENDIX Exi.ATEX</b> .....	<b>10</b>
<b>IV.</b>	<b>APPENDIX Exi.IECEx</b> .....	<b>14</b>
<b>V.</b>	<b>APPENDIX MID</b> .....	<b>17</b>
<b>VI.</b>	<b>FEATURES, INSTALLATION AND MAINTENANCE OF TRANSMITTERS</b> .....	<b>23</b>
<b>1.</b>	<b>INTRODUCTION</b> .....	<b>23</b>
<b>2.</b>	<b>USER MATERIALS</b> .....	<b>23</b>
<b>3.</b>	<b>APPLICATIONS AND MAIN FEATURES</b> .....	<b>23</b>
<b>4.</b>	<b>IDENTIFYING MARKS. ORDERING PROCEDURE</b> .....	<b>24</b>
<b>5.</b>	<b>TECHNICAL DATA</b> .....	<b>24</b>
5.1.	APC..., APR... COMMON PARAMETERS .....	24
5.2.	APC-2000ALW MEASUREMENT RANGES AND METROLOGICAL PARAMETERS .....	26
5.3.	APR-2000ALW, APR-2000ALW/L, APR-2200ALW, APR-2200ALW/L MEASUREMENT RANGES AND METROLOGICAL PARAMETERS .....	27
5.4.	APR-2000GALW, MEASUREMENT RANGES AND METROLOGICAL PARAMETERS .....	29
5.5.	APR-2000YALW, MEASUREMENT RANGES AND METROLOGICAL PARAMETERS .....	29
5.6.	APC-2000ALW/L ... MEASUREMENT RANGES AND METROLOGICAL PARAMETERS .....	30
5.7.	APC ... APR ... ENVIRONMENTAL PARAMETERS .....	31
<b>6.</b>	<b>CONSTRUCTION</b> .....	<b>32</b>
6.1.	PRINCIPLE OF MEASUREMENT. ELECTRONIC SYSTEM CONSTRUCTION .....	32
6.2.	ENCLOSURE OF TRANSMITTERS .....	32
<b>7.</b>	<b>PLACE OF INSTALLATION</b> .....	<b>33</b>
7.1.	GENERAL RECOMMENDATIONS .....	33
7.2.	LOW AMBIENT TEMPERATURE .....	33
7.3.	HIGH MEDIUM TEMPERATURE .....	33
7.4.	MECHANICAL VIBRATION SHOCKS. CORROSIVE MEDIA .....	34
<b>8.</b>	<b>INSTALLATION AND MECHANICAL CONNECTIONS</b> .....	<b>34</b>
8.1.	APC... INSTALLATION AND CONNECTIONS .....	34
8.2.	APR... INSTALLATION AND CONNECTIONS .....	34
8.3.	APR-2000GALW. INSTALLATION AND CONNECTIONS .....	34
8.4.	APR-2000YALW. INSTALLATION AND CONNECTIONS .....	35
8.5.	APC-2000ALW/L ... INSTALLATION AND CONNECTIONS .....	35
<b>9.</b>	<b>ELECTRICAL CONNECTION</b> .....	<b>35</b>
9.1.	GENERAL RECOMMENDATIONS .....	35
9.2.	ELECTRICAL CONNECTIONS FOR APC..., APR... .....	36
9.3.	PROTECTION FROM EXCESS VOLTAGE .....	36
9.4.	EARTHING .....	36
<b>10.</b>	<b>SETTING AND REGULATION</b> .....	<b>36</b>
10.1.	TRANSMITTER RANGE, BASIC RANGE. DEFINITIONS .....	36
10.2.	CONFIGURATION AND CALIBRATION .....	37
<b>11.</b>	<b>INSPECTIONS AND SPARE PARTS</b> .....	<b>47</b>
11.1.	PERIODIC SERVICE .....	47
11.2.	OTHER SERVICES .....	47
11.3.	CLEANING THE DIAPHRAGM SEAL, OVERLOADING DAMAGE .....	47
11.4.	SPARE PARTS .....	47
<b>12.</b>	<b>PACKING, STORAGE AND TRANSPORT</b> .....	<b>47</b>
<b>13.</b>	<b>GUARANTEE</b> .....	<b>48</b>
<b>14.</b>	<b>SCRAPPING, DISPOSAL</b> .....	<b>48</b>
<b>15.</b>	<b>ADDITIONAL INFORMATION</b> .....	<b>48</b>
15.1.	RELATED DOCUMENTS .....	48
<b>16.</b>	<b>FIGURES</b> .....	<b>48</b>
FIG. 1.	APC..., APR... TRANSMITTERS – BLOCK DIAGRAM .....	48
FIG. 2.	ELECTRICAL CONNECTIONS FOR APC..., APR... TRANSMITTERS: .....	49
FIG. 3.	APC-2000ALW SMART PRESSURE TRANSMITTER .....	51
FIG. 4.	APC..., APR... DISPLAY ROTATION POSSIBILITY, CONFIGURATION BUTTONS. ....	52
FIG. 5.	BACK LIGHTING JUMPER VIEW AT TRANSMITTER ELECTRIC BOARD (UNIT DISPLAY BACK SIDE) .....	53
FIG. 6.	M-TYPE CONNECTOR WITH M20x1.5 THREAD .....	54
FIG. 7.	P-TYPE CONNECTOR WITH M20x1.5 THREAD .....	54
FIG. 8.	CM30x2-TYPE CONNECTOR WITH FLUSH DIAPHRAGM WITH M30x2 THREAD .....	54
FIG. 9.	PROCESS CONNECTIONS G1/2" AND G1" .....	55
FIG. 10.	APR-2000ALW DIFFERENTIAL PRESSURE TRANSMITTER WITH C TYPE VENTED COVERS. ....	56
FIG. 11.	APR-2000ALW DIFFERENTIAL PRESSURE TRANSMITTER WITH A SINGLE DIRECT DIAPHRAGM SEAL (EXAMPLE) .....	56
FIG. 12.	EXAMPLE: HOW TO INSTALL THE APR-2200ALW TRANSMITTERS WITH REMOTE DIAPHRAGM .....	57
FIG. 13.	EXAMPLE: HOW TO INSTALL THE APR-2000ALW TRANSMITTER ON A VERTICAL OR HORIZONTAL PIPE .....	58

FIG. 14. EXAMPLE: HOW TO INSTALL THE APR-2000ALW TRANSMITTER WITH A VALVE MANIFOLD TO A 2" PIPE..... 58

FIG. 15. APR-2200ALW DIFFERENTIAL PRESSURE TRANSMITTER WITH TWO REMOTE DIAPHRAGM SEALS (EXAMPLES). ..... 59

FIG. 16. APR-2200ALW DIFFERENTIAL PRESSURE TRANSMITTER WITH DIRECT AND REMOTE DIAPHRAGM SEAL (EXAMPLES). 59

FIG. 17. EXAMPLE: HOW TO INSTALL THE APC..., APR... TRANSMITTER..... 60

FIG. 18. APR-2000GALW SMART DIFFERENTIAL PRESSURE TRANSMITTER FOR LOW RANGES..... 61

FIG. 19. APR-2000YALW SMART LEVEL PROBE FOR PRESSURE TANKS. .... 62

FIG. 20. THE EXPLOSION - PROOF JOINTS OF APC..., APR... TRANSMITTERS. .... 63

FIG. 21. HOW TO LEAD THE CASING OF APC..., APR... TRANSMITTERS..... 63

FIG. 22. APC-2000ALW/LSG... SMART LEVEL TRANSMITTERS. .... 64

FIG. 23. APC-2000ALW/LM & APC-2000ALW/LSP SMART PRESSURE OR LEVEL TRANSMITTERS. .... 65

FIG. 24. AN EXAMPLE OF THE DIFFERENTIAL PRESSURE TRANSMITTER APR-2200ALW/L..... 66

FIG. 25. ADDITIONAL EQUIPMENT FOR FITTING OF PRESSURE TRANSMITTERS. .... 67

## I. APPENDIX Exd.ATEX



**APC-2000ALW/XX PRESSURE TRANSMITTER,  
APR-2000ALW/XX, APR-2200ALW/XX,  
DIFFERENTIAL PRESSURE TRANSMITTERS,  
APR-2000YALW/XX LEVEL PROBE,**

Exd VERSION in accordance with ATEX directive

### 1. Introduction

1.1. This "Appendix Exd.ATEX" applies to transmitters of types **APC-2000ALW/XX, APR-2000ALW/XX, APR-2200ALW/XX** and **APR-2000YALW/XX** in Exd versions only, marked on the rating plate as shown in p.3 and denoted Exd in the Product Certificate.

1.2. The appendix contains supplementary information relating to the Exd (flame-proof) versions compatible with ATEX directive of mentioned transmitters.

During installation and use of Exd transmitters, reference should be made to **DTR.APC.APR.ALW.03(ENG)** in conjunction with "Appendix Exd.ATEX".

### 2. Use of APC..., APR... transmitters in dangers zones

2.1. The transmitters are produced in accordance with the requirements of the following standards: EN 60079-0:2012, EN 60079-1:2007, EN 60079-11:2012, EN 60079-26:2007, EN 60079-31:2009.

2.2. The transmitters may operate in areas where there is a risk of explosion, in accordance with the rating of the explosion protection design:

**I M2 Ex d ia I Mb**

(version with enclosure 1.4401(316))

**II 1/2G Ex ia/d IIC T6/T5 Ga/Gb**

**II 1/2D Ex ia/t IIIC T85°C/T100°C Da/Db**

**KDB 08 ATEX 224X**



marking T6 and T85 applies to range  $-40^{\circ}\text{C} < T_a \leq 45^{\circ}\text{C}$

marking T5 and T100 applies to range  $-40^{\circ}\text{C} < T_a \leq 75^{\circ}\text{C}$

2.3. Transmitter category and hazard areas.

The category 1/2G, contained within the rating, means that the transmitter may be installed within a type 1 or 2 hazard zones. The **APC...**, **APR...** process connections may connect to a 0 zone type (see the diagram below for an example).

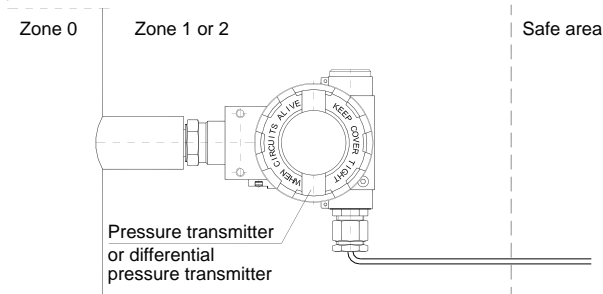

### 3. Identifying marks

Flame-proof transmitters must have a rating plate containing the information specified in p.4 of DTR.APC.APR.ALW.03(ENG) and also at least the following:

- CE mark and number of notified unit;
- "Ex" mark, designation of explosion protection design, certificate number;
- Supply voltage;
- Designation of a process connection;
- Year of manufacture;
- Temperature use range.

In place of XX letters in product rating plate will be written a pressure connection type symbols.

## 4. User information

Together with the ordered transmitters, the user will receive:

- a. Product Certificate;
- b. Declaration of conformity;
- c. Copy of certificate (on request);
- d. User's Manual named: DTR.APC.APR.ALW.03(ENG) with Appendix Exd.ATEX.

Items b), c), d) are available on [www.aplisens.pl](http://www.aplisens.pl)

## 5. Power supply and exploitation of transmitters.

5.1. The transmitter connecting should be made after introduction with present instruction content.



Electrically transmitter should be connected according to scheme at p.6 Appendix Exd.ATEX. Transmitter electrical installation should be realised with engineering standard requirements. Electrical connections of transmitters in danger zone should be made by people who have indispensable knowledge and experience in this branch. Earth clamps must be used to earth transmitters. In the event that transmitters come in contact with structural metal parts or pipes which are connected to the equipotential bonding system, transmitters do not require to be earthed.



5.2. Transmitters should be supplied from DC electrical source with voltage max.45V from transformer feeders or other devices which have at least a strengthened isolation among primary and secondary windings in which don't appear voltage higher than 250V. The duty of power supply installation with above mentioned requirements rests on user.

5.3. Transmitters can be used in ambient temperatures ( $T_a$ ) between  $-40^{\circ}\text{C} < T_a \leq 45^{\circ}\text{C}$  for **class T6** or between  $-40^{\circ}\text{C} < T_a \leq 75^{\circ}\text{C}$  for **T5**.

5.4. Transmitter sensor diaphragm should not be subject on damage during installation and exploitation. The diaphragm is made from 1.4404/1.4435 (316L) or Hastelloy thin foil and cannot be subject on medium which can entail its damage.

5.5. With regard on kind of casing material (light alloy with large aluminium content), the user is obliged to assure, that possibility of hitting casing does not step out in place of transmitter installation.

5.6. In transmitter casing are two holes to assembly of cable glands from thread M20x1.5 or 1/2 NPT.



5.7. Normally transmitters are delivered without installed glands but with blank plugs (corks) in the second hole. The list of cable glands and plugs agreeable with production documentation and accepted by certificate station is specified in Table 1 and Table 2 (p.6 Appendix Exd.ATEX). Customer should install cable glands according to Tables 1 and plugs according to Tables 2 (if plugs aren't installed) or other accordance with flame-proof standards.



5.8. It is necessary to apply a shield cable or without shield cable with round cross-section in protection from elastomer, not moisture absorbing, for example: YKSLY 2 \* 1, YnTKSYekw 1 \* 2 \* 1, LIYCY 2 \* In case of need use cable with different structure, customer should co-ordinate this with transmitters' manufacturer to choose intakes with cable diameter.

5.9. The general principles of connecting and the exploitation of transmitter in Exd realization should be compatible with principles and relating standards for Exd casing devices how in p.2.1 Appendix Exd.ATEX, in this including also: EN 600079-14, EN 60079-17.



5.10. During service must be made a check of the tight fastening of covers and the cable glands and the fastening of the cable in the glands. The casing and supply line must be inspected for mechanical damage, and the transmitter rating plate for legibility. Periodic checks should also be made of the diaphragm, which should not carry signs of damage. During maintenance it is recommended that the threads of the covers be lubricated with non-acid vaseline.



**Because of the transmitter damage possibility, the ambient temperature should not be allowed to become higher than 80°C, even when there is no explosion risk.**

## 6. The electrical connection way of transmitter's series: APC-2000ALW/XX, APR-2000ALW/XX, APR-2200ALW/XX and APR-2000YALW/XX in Exd version

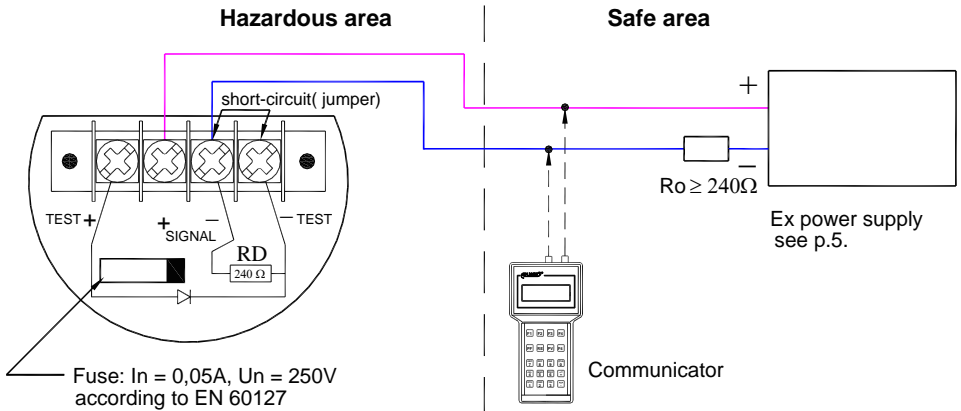

Fig. 2.

In case of transmitter calibration outside danger zone is possible communicator connecting to <SIGNAL+> and <TEST+> terminals. Transmitter is furnished in communication resistor ( $R_D = 240\Omega$ ), closed with jumper at <SIGNAL-> and <TEST-> terminals installed by manufacturer.  $R_D$  resistor can be use then, when it is necessary to communicate with transmitter from its terminals and the load resistance ( $R_o$ ) in current loop is lower then  $240\Omega$ . Than <SIGNAL-> and <TEST-> terminals have to be open.



**In danger zone don't unscrew transmitter covers and don't change the display position or its back lighting.**

Blocking cover method before unscrewing and plumbing possibility is showed at Fig.21.



**It is not permitted to repair or otherwise interfere with the transmitter's electrical circuits in any way. Damage estimation and repair possibility may be assessed by the manufacturer or another authorized party only.**

Table 1. Permitted cable glands

Type	Producer	Screw	Feature	Other marking	No of certificate	
501/423	HAWKE	M20x1.5	Exd IIC	dimension OS, O, A	Baseefa 06 ATEX 0056X	
501/421	HAWKE	M20x1.5	Exd IIC	dimension OS, O, A	Baseefa 06 ATEX 0056X	
ICG 623	HAWKE	M20x1.5	Exd IIC	dimension OS, O, A	Baseefa 06 ATEX 0058X	
501/453	HAWKE	M20x1.5	Exd IIC	dimension OS, O, A	Baseefa 06 ATEX 0056X	*
501/453/RAC	HAWKE	M20x1.5	Exd IIC	dimension OS, O, A	Baseefa 06 ATEX 0056X	*
501/453/Universal	HAWKE	M20x1.5	Exd IIC	dimension OS, O, A	Baseefa 06 ATEX 0057X	*
ICG 653	HAWKE	M20x1.5	Exd IIC	dimension OS, O, A	Baseefa 06 ATEX 0058X	*
8163/2-A2F	STAHL	M20x1.5	Exd IIC		SIRA06ATEX1188X	
A2F, A2FRC, SS2K	CMP-Products	M20x1.5	Exd IIC		SIRA06ATEX1097X	
E1FW, E1FX/Z, E2FW, E2FX/Z	CMP-Products	M20x1.5	Exd IIC		SIRA06ATEX1097X	*
T3CDS, T3CDSPB	CMP-Products	M20x1.5	Exd IIC		SIRA06ATEX1283X	*
PX2K, PXSS2K, PX2KX, PXB2KX	CMP-Products	M20x1.5	Exd IIC		SIRA06ATEX1097X	*

Table 2. Permitted plugs

Type	Producer	Screw	Feature	Other marking	No certificate	
	AGRO AG	M20x1.5	Exd IIC			
475	HAWKE	M20x1.5	Exd IIC			
477	HAWKE	M20x1.5	Exd IIC			

\*) for special cable only.

### Special conditions for safe use:

- Permissible gap of joint marked in documentation by L4 is smaller than this was defined in norm EN 60079-1:2007 and cannot be greater than passed value on Fig. 20.
- As the replacing elements, can be used only those specified in the descriptive documentation.



## II. APPENDIX Exd.IECEx

**APC-2000ALW/XX PRESSURE TRANSMITTER,  
APR-2000ALW/XX, APR-2200ALW/XX,  
DIFFERENTIAL PRESSURE TRANSMITTERS,  
APR-2000YALW/XX LEVEL PROBE**

Exd VERSION in accordance with IECEx certificate

### 1. Introduction

**1.1. This “Appendix Exd.IECEx” applies to transmitters of types APC-2000ALW/XX, APR-2000ALW/XX, APR-2200ALW/XX and APR-2000YALW/XX in Exd versions only, marked on the rating plate as shown in p.3 and denoted Exd in the Product Certificate.**

**1.2. The appendix contains supplementary information relating to the Exd (flame-proof) versions compatible with IECEx certificate of mentioned transmitters.**

During installation and use of Exd transmitters, reference should be made to **DTR.APC.APR.ALW.03(ENG)** in conjunction with “Appendix Exd.IECEx”.

### 2. Use of APC..., APR... transmitters in dangers zones

2.1. The transmitters are produced in accordance with the requirements of the following standards:

IEC 60079-0:2007-10 ed.5, IEC 60079-1:2007-04 ed.6, IEC 60079-11:2006 ed.5, IEC 60079-31:2008 ed.1, IEC 60079-26:2006 ed.2.

2.2. The transmitters may operate in areas where there is a risk of explosion, in accordance with the rating of the explosion protection design:

**Ex d ia I Mb**

(version with enclosure 1.4401 (316))

**Ex ia/d IIC T6/T5 Ga/Gb**

**Ex ia/t IIIC T85°C/T100°C Da/Db**

**IECEx KDB 14.0001X**

marking T6 and T85 applies to range  $-40^{\circ}\text{C} < T_a \leq 45^{\circ}\text{C}$

marking T5 and T100 applies to range  $-40^{\circ}\text{C} < T_a \leq 75^{\circ}\text{C}$

2.3. Equipment protection level (EPL) and hazard areas.

Equipment protection level (EPL) Ga/Gb (Da/Db), contained within the rating, means that the transmitter may be installed within a type 1 (21) or 2 (22) danger zone. Process connections can connect to zone 0 (20) (example shown below). Intrinsically safe transmitter marked Mb turn off if there is risk of an explosive atmosphere.

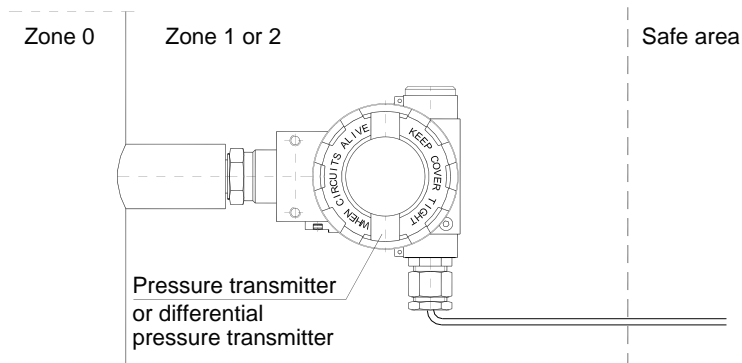

### 3. Identifying marks

Flame-proof transmitters must have a rating plate containing the information specified in p.4 of DTR.APC.APR.ALW.03(ENG) and also at least the following:

- Designation of explosion protection design, certificate number;
- Supply voltage;
- Designation of a process connection;
- Year of manufacture;
- Temperature use range.

In place of XX letters in product rating plate will be written a pressure connection type symbols.

### 4. User information

Together with the ordered transmitters, the user will receive:

- a. Product Certificate;
- b. Declaration of conformity (on request);
- c. Copy of certificate (on request);
- d. User's Manual named: DTR.APC.APR.ALW.03(ENG) with Appendix Exd.IECEx.

Items b), c), d) are available on [www.aplisens.pl](http://www.aplisens.pl)

### 5. Power supply and exploitation of transmitters

5.1. The transmitter connecting should be made after introduction with present instruction content.

Electrically transmitter should be connected according to scheme at p.6 Appendix Exd.IECEx.

**i**

Transmitter electrical installation should be realised with engineering standard requirements. Electrical connections of transmitters in danger zone should be made by people who have indispensable knowledge and experience in this branch. Earth clamps must be used to earth transmitters. In the event that transmitters come in contact with structural metal parts or pipes which are connected to the equipotential bonding system, transmitters do not require to be earthed.

**i**

5.2. Transmitters should be supplied from DC electrical source with voltage max.45V from transformer feeders or other devices which have at least a strengthened isolation among primary and secondary windings in which don't appear voltage higher than 250V. The duty of power supply installation with above mentioned requirements rests on user.

5.3. Transmitters can be used in ambient temperatures ( $T_a$ ) between  $-40^{\circ}\text{C} < T_a \leq 45^{\circ}\text{C}$  for class T6 or between  $-40^{\circ}\text{C} < T_a \leq 75^{\circ}\text{C}$  for T5.

5.4. Transmitter sensor diaphragm should not be subject on damage during installation and exploitation. The diaphragm is made from 1.4404/1.4435 (316L) or Hastelloy thin foil and cannot be subject on medium which can entail its damage.

5.5. With regard on kind of casing material (light alloy with large aluminium content), the user is obliged to assure, that possibility of hitting casing does not step out in place of transmitter installation.

5.6. In transmitter casing are two holes to assembly of cable glands from thread M20x1.5 or 1/2 NPT.

**i**

5.7. Normally transmitters are delivered without installed glands but with blank plugs (corks) in the second hole. The list of cable glands and plugs agreeable with production documentation and accepted by certificate station is specified in Table 1 and Table 2 (p.6 Appendix Exd.ATEX). Customer should install cable glands according to Tables 1 and plugs according to Tables 2 (if plugs aren't installed) or other accordance with flame-proof standards.

**i**

5.8. It is necessary to apply a shield cable or without shield cable with round cross-section in protection from elastomer, not moisture absorbing, for example: YKSLY 2 \* 1, YnTKSYekw 1 \* 2 \* 1, LIYCY 2 \* In case of need use cable with different structure, customer should co-ordinate this with transmitters' manufacturer to choose intakes with cable diameter.

5.9. The general principles of connecting and the exploitation of transmitter in Exd realization should be compatible with principles and relating standards for Exd casing devices how in p.2.1 Appendix Exd.IECEx, in this including also: IEC 600079-14, IEC 60079-17.

**i**

5.10. During service must be made a check of the tight fastening of covers and the cable glands and the fastening of the cable in the glands. The casing and supply line must be inspected for mechanical damage, and the transmitter rating plate for legibility. Periodic checks should also be made of the diaphragm, which should not carry signs of damage. During maintenance it is recommended that the threads of the covers be lubricated with non-acid vaseline.



Because of the transmitter damage possibility, the ambient temperature should not be allowed to become higher than 80°C, even when there is no explosion risk.



It is not permitted to repair or otherwise interfere with the transmitter's electrical circuits in any way. Damage estimation and repair possibility may be assessed by the manufacturer or another authorized party only.



In danger zone don't unscrew transmitter covers and don't change the display position or its back lighting.

## 6. The electrical connection way of transmitter's series: APC-2000ALW/XX, APR-2000ALW/XX, APR-2200ALW/XX and APR-2000YALW/XX in Exd version

- According to the p.6 DTR.APC.APR.ALW.03(ENG) Appendix Exd.ATEX.

### Special conditions for safe use:

- Permissible gap of joint marked in documentation by L4 is smaller than this was defined in norm IEC 60079-1:2006 ed.5 and cannot be greater than passed value on Fig. 20.
- As the replacing elements, can be used only those specified in the descriptive documentation.

### III. APPENDIX Exi.ATEX



**APC-2000ALW PRESSURE TRANSMITTER,  
APR-2000ALW, APR-2200ALW, APR-2000GALW,  
APR-2000ALW/L, APR-2200ALW/L  
DIFFERENTIAL PRESSURE TRANSMITTERS,  
APR-2000YALW LEVEL PROBE,  
APC-2000ALW/L LEVEL TRANSMITTER**

Ex VERSION in accordance with ATEX directive

#### 1. Introduction

1.1. This "Appendix Exi.ATEX" applies to transmitters of types **APC-2000ALW, APR-2000ALW, APR-2200ALW, APR-2000GALW, APC-2000ALW/L, APR-2000ALW/L, APR-2200ALW/L and APR-2000YALW** in Ex versions only, marked on the rating plate as shown in p.2.2 and denoted Ex in the Product Certificate.

1.2. The appendix contains supplementary information relating to the Ex versions compatible with ATEX directive of mentioned transmitters.

During installation and use of Ex transmitters, reference should be made to **DTR.APC.APR.ALW.03(ENG)** in conjunction with "Appendix Exi.ATEX".

#### 2. Use of APC..., APR... transmitters in danger zones

2.1. The transmitters are produced in accordance with the requirements of the following standards: EN 60079-0:2012, EN 60079-26:2007, EN 60079-11:2012, EN 50303:2000.

2.2. The transmitters may operate in areas where there is a risk of explosion, in accordance with the rating of the explosion protection design:



**II 1/2G Ex ia IIC T5/T6 Ga/Gb**  
**II 1/2G Ex ia IIB T5/T6 Ga/Gb** (version with Teflon-shielded cable)  
**II 1D Ex ia IIIC T105°C Da**  
**I M1 Ex ia I Ma** (version with enclosure 1.4401 (316))  
**FTZÚ 08 ATEX 0020X**

For "Version SC" and "Version SC, SA":

**II 1/2G Ex ia IIC T4/T5 Ga/Gb**  
**II 1/2G Ex ia IIB T4/T5 Ga/Gb** (version with Teflon-shielded cable)  
**II 1D Ex ia IIIC T105°C Da**  
**I M1 Ex ia I Ma** (version with enclosure 1.4401 (316))  
**FTZÚ 08 ATEX 0020X**

#### 2.3. Transmitter category and hazard areas

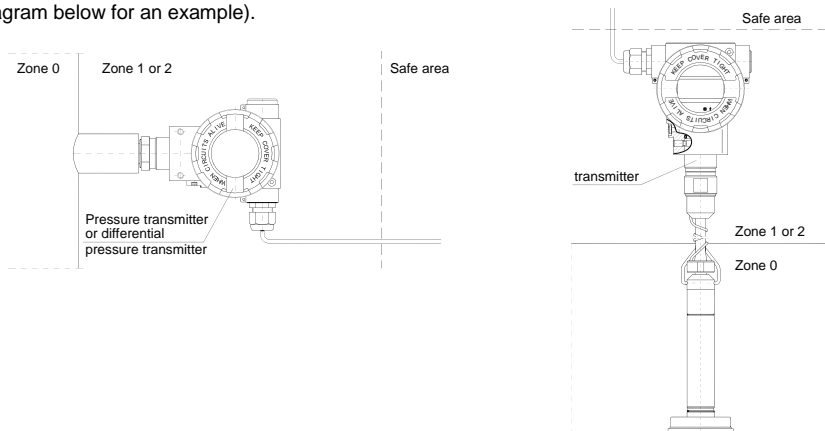
The category 1/2G, contained within the rating, means that the transmitter may be installed within a type 1 or 2 hazard zones. The **APC..., APR...** process connections may connect to a 0 zone type (see the diagram below for an example).



### 3. Identifying marks

Intrinsically safe transmitters must have a rating plate containing the information specified in paragraph 4 of DTR.APC.APR.ALW.03(ENG) and also at least the following:

- CE mark and number of notified unit:  mark;
- Designation of explosion protection design, certificate number;
- Values of parameters such as:  $U_i$ ,  $I_i$ ,  $P_i$ ,  $C_i$ ,  $L_i$ ;
- Year of manufacture;
- Text: "Version SA", "Version SC, SA" - separate power supply for transmitters with surge arresters. Power supply must be separate to earth.

### 4. User information

Together with the ordered transmitters, the user will receive:

- a) Product Certificate;
- b) Declaration of conformity;
- c) Copy of certificate (on request);
- d) User's Manual named: DTR.APC.APR.ALW.03(ENG) with Appendix Exi.ATEX.

Items b), c), d) are available on [www.aplisens.pl](http://www.aplisens.pl)

### 5. Permitted input parameters (based on data from the FTZÚ 08 ATEX 0020X certificate, and certification documentation)



The transmitters should be powered via the associated power feeding and measurement devices provided with the relevant intrinsic-safe certificates. The parameters of their outputs to the danger zone should not exceed the limit power supply parameters for the below specified transmitters.



**Note: Transmitters marked on the nameplate as "Version SC" or "Version SC, SA" have other input parameters see section 5.1, 5.3, 5.5 of Appendix Exi.ATEX.**

**5.1.** For power supply with an linear output characteristic in „Version SC" or “Version SC, SA" version

$$U_i = 28V \quad I_i = 0.1A \quad P_i = 0.7W \quad -40^\circ C \leq T_a \leq 70^\circ C \text{ and } T_5$$

**5.2.** For power supply with a linear output characteristic

$$U_i = 30V \quad I_i = 0.1A \quad P_i = 0.75W \quad -40^\circ C \leq T_a \leq 40^\circ C \text{ and } T_6, -40^\circ C \leq T_a \leq 80^\circ C \text{ and } T_5$$

Power supply with a linear characteristic may be e.g. a typical barrier with parameters

$$U_o = 28V \quad I_o = 0.093A \quad R_w = 300\Omega.$$

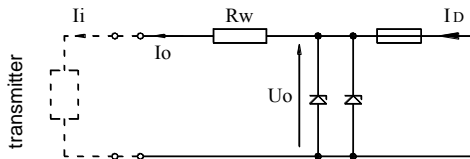

Fig.1. Power supply from a source with linear characteristic.

**5.3.** For power supply with a trapezoidal output characteristic in „Version SC" or “Version SC, SA"

$$U_i = 24V \quad I_i = 50mA \quad P_i = 0.7W \quad -40^\circ C \leq T_a \leq 80^\circ C \text{ and } T_5$$

**5.4.** For power supply with a trapezoidal output characteristic

$$U_i = 24V \quad I_i = 50mA \quad P_i = 0.7W \quad -40^\circ C \leq T_a \leq 80^\circ C \text{ and } T_5$$

Example of power supply from a source with trapezoidal characteristic (see Fig. 2).

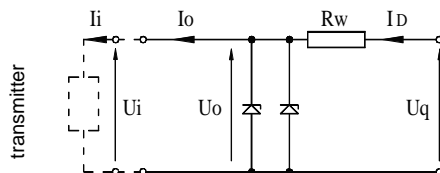

Fig. 2. Power supply from a source with trapezoidal characteristic.

If  $U_o < \frac{U_q}{2}$  then parameters  $U_q$ ,  $I_o$ ,  $P_o$  are interrelated as follows:

$$U_q = \frac{4P_o}{I_o}, \quad R_w = \frac{U_q}{I_o}, \quad P_o = \frac{U_o(U_q - U_o)}{R_w} \quad \text{for } U_o \leq 1/2U_q$$

**5.5.** For power supply with a rectangular output characteristic in „Version SC“ or “Version SC, SA”

$$U_i = 24V \quad I_i = 25mA \quad P_i = 0.6W \quad -40^\circ C \leq T_a \leq 80^\circ C \text{ and } T_5$$

$$U_i = 24V \quad I_i = 50mA \quad P_i = 1.2W \quad -40^\circ C \leq T_a \leq 80^\circ C \text{ and } T_4$$

**5.6.** For power supply with a rectangular output characteristic

$$U_i = 24V \quad I_i = 25mA \quad P_i = 0.6W \quad -40^\circ C \leq T_a \leq 40^\circ C \text{ and } T_6, -40^\circ C \leq T_a \leq 80^\circ C \text{ and } T_5$$

$$U_i = 24V \quad I_i = 50mA \quad P_i = 1.2W \quad -40^\circ C \leq T_a \leq 70^\circ C \text{ and } T_5,$$

The supply of power from a source with a rectangular characteristic means that the voltage of the Ex power supply remains constant until current limitation activates.

The protection level of power supplies with a rectangular characteristic is normally “ib”.

The transmitter powered from such a supply is also an Ex device with protection level “ib”.

Example of practical provision of power supply.

– use a stabilized power supply with  $U_o=24V$  with protection level „ib“ and current limited to  $I_o=25mA$ .

**5.4.** Input inductance and capacity

$$C_i=2.5nF, \quad L_i=18\mu H$$

**5.6.** Supply voltage min.: 10.5VDC

For „Version SC“ or „Version SC, SA“: 13.5V DC

**5.7.** Load resistance:

- from 28V linear supply

$$R_o \text{ max } [\Omega] = \frac{28V - 10.5V^{**} - (300\Omega \cdot 0.0225A)}{0.0225A}$$

- from a source with trapezoidal or rectangular characteristic supply

$$R_o \text{ max } [\Omega] = \frac{U_{sup} - 10.5V^{**}}{0.0225A}$$

\*) *barrier resistance*;

\*\*) 13.5V DC for “Version SC” and “Version SC, SA”.

## 6. How to connect Ex transmitters APC..., APR...

The transmitter and other devices in the measuring loop should be connected in accordance with the intrinsic-safety and explosion-safety regulations and the conditions for use in dangerous areas.



Failure to observe the intrinsic-safety regulations can cause explosion and the resulting hazard to people.

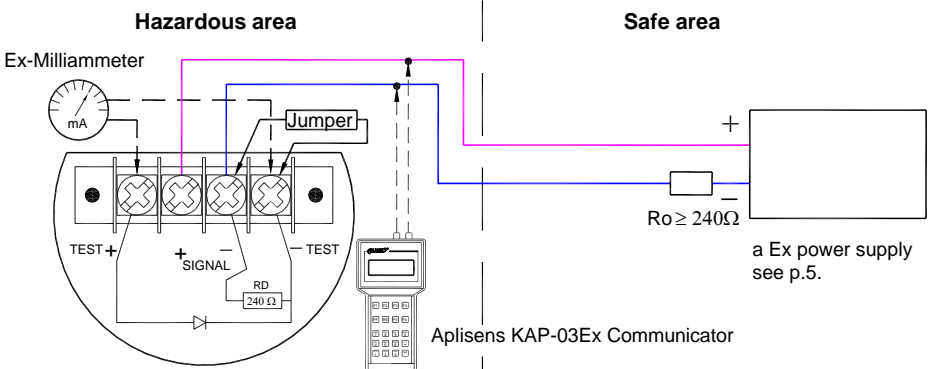

To measure the current in the transmitter without disconnecting the signalling circuit, connect a milliammeter to transmitter terminals TEST+, TEST-.



In hazardous areas, connections to the control terminals must be made using only instruments which are permitted to be used in such areas.



The transmitter is equipped in additional communication resistor RD = 240Ω. During normal operation terminals <SIGNAL →> and <TEST →> are shorted. RD resistor is used when you wish to communicate with the transmitter locally (from its terminals) and  $R_o < 240\Omega$ . Terminals <SIGNAL →> and <TEST →> must be opened.



If the temperature of the medium exceeds  $T_a$ , then suitable separators such as membrane separators or P-type siphon tubes must be used. Transmitter working temperature ( $T_p$ ) must conform to  $T_p \leq T_a$ .

### Special conditions for safe use:



Version of transmitter with surge arrester, marked on the plate "Version SA", "Version SC, SA" does not meet the requirements of Section 10.3 of the EN 60079-11:2012 (500Vrms). This must be taken into account when installing the equipment.

Transmitter electrical installation should be realised with engineering standard requirements.



It is not allowed to repair or otherwise interfere with the transmitter's electrical circuits in any way. Damage and possible repair may be assessed only by the manufacturer or another authorized party.

## IV. APPENDIX Ex.IECEX

**APC-2000ALW PRESSURE TRANSMITTER,  
APR-2000ALW, APR-2200ALW, APR-2000GALW,  
APR-2000ALW/L, APR-2200ALW/L**  
DIFFERENTIAL PRESSURE TRANSMITTERS,  
**APR-2000YALW LEVEL PROBE,  
APC-2000ALW/L LEVEL TRANSMITTER**  
Ex VERSION in accordance with IECEx certificate

### 1. Introduction

1.1. This "Appendix Ex.IECEX" applies to transmitters of types **APC-2000ALW, APR-2000ALW, APR-2200ALW, APR-2000GALW, APC-2000ALW/L, APR-2000ALW/L, APR-2200ALW/L and APR-2000YALW** in Ex versions only, marked on the rating plate as shown in p.2.2 and denoted Ex in the Product Certificate.

1.2. The appendix contains supplementary information relating to the Ex versions compatible with IECEx certificate of mentioned transmitters.

During installation and use of Ex transmitters, reference should be made to **DTR.APC.APR.ALW.03(ENG)** in conjunction with "Appendix Ex.IECEX".

### 2. Use of APC..., APR... transmitters in danger zones

2.1. The transmitters are produced in accordance with the requirements of the following standards: IEC 60079-0:2011 ed. 6.0, IEC 60079-26:2006 ed. 2.0, IEC 60079-11:2011 ed. 6.0.

2.2. The transmitters may operate in areas where there is a risk of explosion, in accordance with the rating of the explosion protection design:

**Ex ia IIC T5/T6 Ga/Gb**

**Ex ia IIB T5/T6 Ga/Gb**

**Ex ia IIIC T105°C Da**

**Ex ia I Ma**

(version with Teflon-shielded cable)

(version with enclosure 1.4401 (316))

**IECEx FTZÚ 14.0026X**

2.3. Equipment protection level (EPL) and hazard areas.

Equipment protection level (EPL) Ga/Gb, contained within the rating, means that the transmitter may be installed within a type 1 or 2 danger zone. Process connections can connect to zone 0 (example shown below).

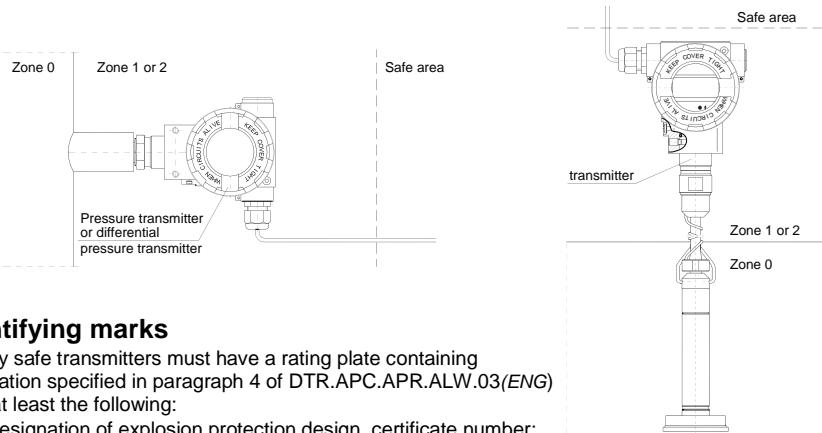

### 3. Identifying marks

Intrinsically safe transmitters must have a rating plate containing the information specified in paragraph 4 of DTR.APC.APR.ALW.03(ENG) and also at least the following:

- Designation of explosion protection design, certificate number;
- Values of parameters such as:  $U_i$ ,  $I_i$ ,  $P_i$ ,  $C_i$ ,  $L_i$ ;
- Year of manufacture;
- Text: "Version SA" - separate power supply for transmitters with surge arresters. Power supply must be separate to earth.



## 4. User information

Together with the ordered transmitters, the user will receive:

- Product Certificate;
- Declaration of conformity (on request);
- Copy of certificate (on request);
- User's Manual named: DTR.APC.APR.ALW.03(ENG) with Appendix Exi.IECEx.

Items b), c), d) are available on [www.aplisens.pl](http://www.aplisens.pl)

## 5. Permitted input parameters (based on data from the IECEx FTZÚ 14.0026X certificate, and certification documentation)



The transmitters should be powered via the associated power feeding and measurement devices provided with the relevant intrinsic-safe certificates. The parameters of their outputs to the danger zone should not exceed the limit power supply parameters for the below specified transmitters.

### 5.1. For power supply with a linear output characteristic

$U_i = 30V$   $I_i = 0.1A$   $P_i = 0.75W$   $-40^\circ C \leq T_a \leq 40^\circ C$  and T6,  $-40^\circ C \leq T_a \leq 80^\circ C$  and T5

Power supply with a linear characteristic may be e.g. a typical barrier with parameters

$U_o = 28V$   $I_o = 0.093A$   $R_w = 300\Omega$ .

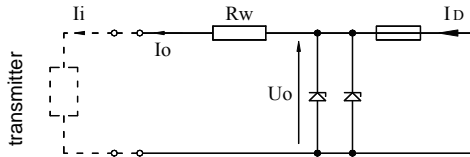

Fig.1. Power supply from a source with linear characteristic.

### 5.2. For power supply with a trapezoidal output characteristic

$U_i = 24V$   $I_i = 50mA$   $P_i = 0.7W$   $-40^\circ C \leq T_a \leq 80^\circ C$  and T5

Example of power supply from a source with trapezoidal characteristic (see Fig. 2).

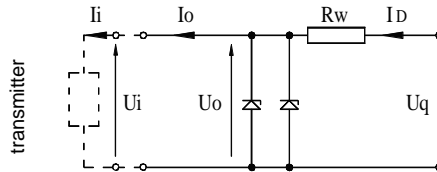

Fig. 2. Power supply from a source with trapezoidal characteristic.

If  $U_o < \frac{U_q}{2}$  then parameters  $U_q$ ,  $I_o$ ,  $P_o$  are interrelated as follows:

$$U_q = \frac{4P_o}{I_o}, \quad R_w = \frac{U_q}{I_o}, \quad P_o = \frac{U_o(U_q - U_o)}{R_w} \quad \text{for } U_o \leq 1/2U_q$$

### 5.3. For power supply with a rectangular output characteristic

$U_i = 24V$   $I_i = 25mA$   $P_i = 0.6W$   $-40^\circ C \leq T_a \leq 40^\circ C$  and T6,  $-40^\circ C \leq T_a \leq 80^\circ C$  and T5

$U_i = 24V$   $I_i = 50mA$   $P_i = 1.2W$   $-40^\circ C \leq T_a \leq 70^\circ C$  and T5,

The supply of power from a source with a rectangular characteristic means that the voltage of the Ex power supply remains constant until current limitation activates.

The protection level of power supplies with a rectangular characteristic is normally "ib".

The transmitter powered from such a supply is also an Ex device with protection level "ib".

Example of practical provision of power supply.

– use a stabilized power supply with  $U_o=24V$  with protection level „ib” and current limited to  $I_o=25mA$ .

### 5.4. Input inductance and capacity

$C_i=2.5nF$ ,  $L_i=18\mu H$

### 5.6. Supply voltage min.: 10.5VDC

**5.7. Load resistance:**

- from 28V linear supply

$$R_{o \max} [\Omega] = \frac{28V - 10.5V - (300\Omega \cdot 0.0225A)}{0.0225A}$$

- from a source with trapezoidal or rectangular characteristic supply

$$R_{o \max} [\Omega] = \frac{U_{sup} - 10.5V}{0.0225A}$$

\*) *barrier resistance.*

**6. How to connect Ex transmitters APC..., APR...**

- According to the p.6 DTR.APC.APR.ALW.03(ENG) Appendix Exi.ATEX.

**Special conditions for safe use:**

Version of transmitter with surge arrester, marked on the plate "Version SA" does not meet the requirements of Section 10.3 of IEC 60079-11:2011 (500Vrms). This must be taken into account when installing the equipment.

Transmitter electrical installation should be realised with engineering standard requirements.



**It is not allowed to repair or otherwise interfere with the transmitter's electrical circuits in any way. Damage and possible repair may be assessed only by the manufacturer or another authorized party.**

## V. APPENDIX MID



### APC-2000ALW PRESSURE TRANSMITTERS, GAUGE and ABSOLUTE, APPLICATIONS ACCORDANCE IN EN 12405-1:2005+A2:2010 STANDARD

#### 1. INTRODUCTION

1.1. The "MID Appendix" applies only to the APC-2000ALW absolute / relative transmitters applications where they are as instruments for use in/as measuring devices (MI-002 gas) in accordance with the EN 12405-1:2005+A2:2010 standard harmonized to Measuring Instruments Directive (MID) 2004/22, and the OIML R140:2007 recommendations.

1.2. The appendix contains the transmitters data to realizations them to uses in metrology. During the installation and use of pressure transmitters in the MID version, is necessary to use the DTR.APC.APR.ALW.03(ENG) together with MID Appendix - in situations of ambiguous interpretations of text connected with installation and service of transmitters made according to MID version the final resolution is as written in MID Appendix.

#### 2. APC-2000ALW transmitters in MID version. Inscriptions

APC-2000ALW transmitters made for MID applications have a rating plates on which there are at least given below information:

		APLISENS S.A. 03-102 WARSZAWA ul. Mirowska 7 T. +48 22 814 07 77 F. +48 22 814 07 78 POLAND	
smart pressure transmitter			
type APC-2000ALW/ XX			
$P$	=	---	MPa
$P_{max}$	=	----	MPa
$t_{amb, min}$	=	-25 °C	$t_{amb, max}$ = 55 °C
$U_{supl.}$	=	---	V DC
$I_{output}$	=	4...20mA DC + HART	
Ser.-No	-----		
Year of production	-----		
Mat.	-----		
version in accordance with EN 12405-1+A2:2010			
Part's Certificate No. --- --			
-----			
ATEX certificates designation: Exi or Exd			
-----			

An APC-2000ALW transmitter for MID applications distinguishes from the other applications by information at rating plate that is made in accordance with EN 12405-1:2005+A2:2010 and is written a Number of Parts Certificate. In place of the XX in the transmitter type is given the type of connection to the pressure installation. Units of pressure on the rating plate of bars and MPa are used interchangeably.

#### 3. APC-2000ALW transmitters in MID version. Application

3.1. Pressure Transmitters Series APC-2000ALW, version in accordance with EN 12405-1:2005+A2:2010, are provided for use in gas volume conversion devices of type 2, equipped with a backup electrical power source (battery, UPS) for gaseous fuels first and second families according to EN 437.

3.2. Using transmitters in the danger zones.

All APC-2000ALW transmitters in version according to EN 12405-1:2005+A2:2010 are Intrinsically Safe (Exi) or Flame-proof (Exd), and as such are made in accordance with the standards set out in Exi or Exd Annex. Transmitters in the version in accordance to EN 12405-1:2005+A2:2010 can operate in hazardous areas in accordance to the designation of explosin-proof construction. Specific parameters of the Exi or Exd application, according to ATEX, with certificate numbers are given on the nameplate of the transmitter.

APC-2000ALW intrinsically safe pressure transmitters in MID version have the following input parameters:  $Ci = 30nF$ ,  $Li = 0.75mH$ ,  $-25^{\circ}C \leq Ta \leq 55^{\circ}C$ . Other parameters are in accordance with "Exi.ATEX Appendix". APC-2000ALW flame-proof pressure transmitters in MID version have the temperature range:  $-25^{\circ}C \leq Ta \leq 55^{\circ}C$ , other parameters are in accordance with "Exd.ATEX Appendix". During installation and use of pressure transmitters in the MID version to be followed these parameters and other data contained in "**Appendix Exi.ATEX**" or "**Appendix Exd.ATEX**" to Manual.



## 4. List of completeness

Together with APC-2000ALW transmitter user receives:

- Product Certificate which is also a warranty;
- Declaration of Conformity - on request;
- User's Manual;
- Copies of certificates - on request;
- Calibration certificate - on request.

Items: b, c, d can be found at: [www.aplisens.pl](http://www.aplisens.pl)

## 5. APC-2000ALW for MID applications. Technical parameters

Transmitter supply (Usup)	13.5* ÷ 28V DC	for Exi versions
	13.5* ÷ 45V DC	for Exd versions
Output signal	4÷20mA + HART	
Ambient temperature	-25 ÷ 55°C	
Relative humidity	10 ÷ 98% with condensation	
Case protection ingress (according to EN 60529)	IP 66	

\*) *Backlight setting of indicates increases the minimum supply voltage by 3V. Display backlight is switched on by the manufacturer at the order of the customer. In standard transmitters the backlight is turned off.*



For the needs of clearing, in accordance with Directive 2004/22/EC, should be used one of the two metrological checked transmitter output signals: digital HART signal or loop current signal.



Ingress case protection for gaseous fuels 1 and 2 family in accordance with EN 437 provides a design of transmitter case and cable glands and plugs with seals of the HNBR, or TPE. In the situation of its own cable glands and plugs you should use components dedicated to Ex zones, to ensure: temperature, resistance to fuel gas families 1 and 2 and the above degree of protection. Can be used cable glands with sealants such as TPE's for example: EX1100.20.110 AGRO.

### 5.1. Transmitters environmental parameters in the MID version

Products in this embodiment meets the following requirements; criteria by EN 12405-1:2005+A2:2010.

#### 5.1.1. Electromagnetic Compatibility, immunity

*Electrostatic Discharge (ESD):*

EN 61000-4-2

Level 4,

Contact: ±8kV

Air: ±15kV

Criterion A,

*Conducted Radio Frequency:*

EN 61000-4-6

Level 3

0.15... 80MHz - 10V

Criterion A,

*Radiated Electromagnetic Field:*

EN 61000-4-3

Level 3

80 ... 1 000MHz – 10V/m

1 ... 2.700GHz – 1V/m

Criterion A,

*Magnetic Field:*

EN 61 000-4-8

Level 4

*Electrical Fast Transient (Burst):*

EN 61000-4-4

± 2kV, I/O

*Electrical Slow Transient (Surges):*

EN 61000-4-5

Level 3

#### 5.1.2 Short drops in electrical supply

EN 61000-4-29

Level 1

#### 5.1.3. Climatic Immunity

The transmitters can be installed in different climatic conditions (see p.7 DTR.APC.APR.ALW.03(ENG)) in environments of varying humidity, also in areas of water vapour condensation.

*Environment temperature:*

EN 60068-2-1, EN 60068-2-2, EN60068-3-1

hot: T = 55°C, R<sub>H</sub> = max 55%

cold: T = -25°C,

*Humid Permanent Heat:*

EN60068-2-78

T=55°C, R<sub>H</sub>=93%, 96h

*Damp Heat Cycle:*

EN 60068-2-30

(T = 22 ÷ 55°C, R<sub>H</sub> = 80 ÷ 100%, 24h)x2

#### 5.1.4. Mechanical Immunity

*Shocks:*

EN 60068-2-31, level 2

*Vibrations in a wide band:*

EN 60068-2-64, test Fh, level 2

### 5.2. Connectors to pressure installation

Connecting your pressure install with a transmitter should be made in accordance with the requirements for an installation using the transmitter connector. Transmitters in the MID version are equipped with one of the following types of Aplsens pressure ports: M, P, G1/2 G1/4, GP, R1/2, 1/2NPT (see p.5.2.4 DTR.APC.APR.ALW.03(ENG)). Pressure connection type, which designation given is the type of transmitter, the purchaser should agree with the manufacturer. Transmitters in the MID version do not provide connections to the diaphragm seals.

### 5.3. APC-2000ALW for MID applications. Electrical connections to the transmitter

In measuring systems according to EN 12405-1:2005+A2:2010 APC-2000ALW transmitters in MID version connecting to measuring install is always a two wire. For the connection of power and signal receiving terminals <SIGNAL+> and <SIGNAL-> of transmitter should be used with the polarization behavior - < + > to <SIGNAL+>; < - > to <SIGNAL->. Terminals < TEST +> and < TEST - > of transmitter in the metrological applications are not used. The cable shield should be connected one-sidedly to grounding - the manufacturer recommends connect the shield to the converter installation grounding point. The way of APC-2000ALW transmitter connecting to measurement installation in MID applications is shown in Figure 1a.

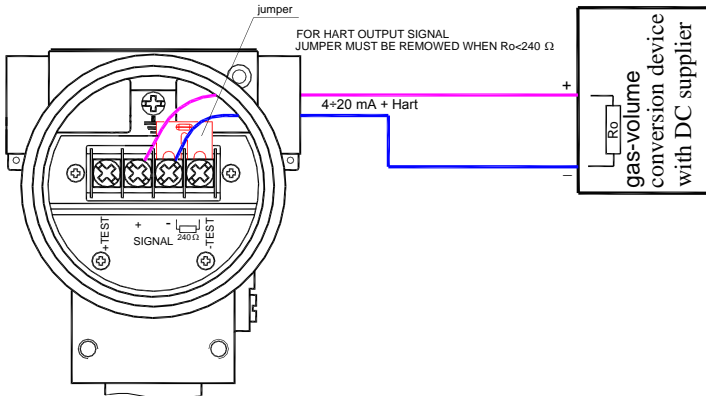

Fig. 1a. APC-2000ALW for MID application.  
Connecting diagram of transmitter to powering and measuring installation.

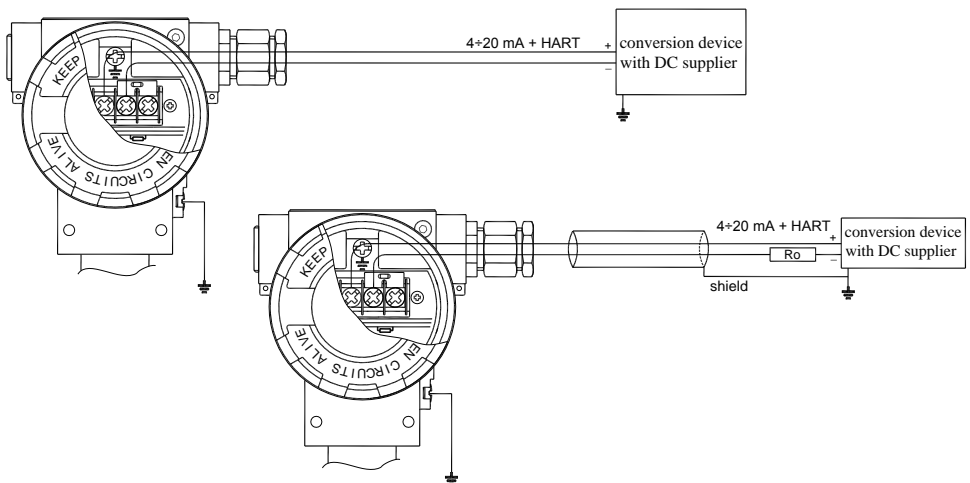

Fig. 1b. APC-2000ALW pressure transmitter for MID application.  
Recommended by manufacturer way of earthing to the measuring system.

For electrical connection should be use twisted pair cable; shielded or not shielded, flexible, with diameter  $5\text{mm} \leq \phi \leq 9\text{mm}$ , complies to ATEX standards. Example of the type of cable is shown below.

Producer	Technokabel	LAPPKABEL
Type (not shielded)	IB-YSLY 2x0.75 *	ÖLFLEX® EB 2X1 (nr art. 0012440)
Type (shielded)	IB-YSLCY 2x0.75	ÖLFLEX® EB CY 2X1 (nr art. 0012650)

\*) Maximum conductors cross-section: 2.5mm.

Grounding to the transmitter should be performed according to the gas-volume conversion device documentation. To transmitter grounding should be used external earthing terminal if grounding by pressure connector is not enough. An exemplary method of grounding of pressure measuring system is shown in Figure 1b.

#### 5.4. Cable entries (glands).

Transmitters in the MID version are equipped with cable entries which meet the ATEX requirements (see Appendix Exi.ATEX and Appendix Exd.ATEX) and the requirements of EN 12405-1:2005+A2:2010. In order to facilitate the adaptation of transmitter installation parameters for user-specific installation requirements, in agreement with the user, transmitters can be supplied without glands and plugs. Then user must verify and approve applied own cable inlets and plugs which will use for compliance with the requirements of ATEX, IP and EN 12405-1:2005+A2:2010.

## 6. APC-2000ALW for MID application. Measurement ranges and metrological parameters

### 6.1. APC-2000ALW for MID application. Measurement ranges. Overpressure

Range	Absolute/gauge	Maximum pressure
<b>30 ... 100 bar *</b>	absolute	100 bar
<b>2 ... 20 bar</b>	absolute	20 bar
<b>2 ... 20 bar</b>	gauge	20 bar
<b>0.9 ... 7 bar</b>	absolute	7 bar
<b>0.9 ... 7 bar</b>	gauge	7 bar

\*) According to EN 12405-1:2005+A2:2010 pressure units: bar and MPa can be used interchangeably.

Measuring range of transmitters is setting by the manufacturer. Blocking against changes in the transmitter settings can be made as follows:

- systemically, by HART System, activated by a configuration program (Report 2) and protected by password;
- "spec MID locking" done with local buttons on the transmitter with a local menu (command MID\_WP).



For pressure transmitters complying to MID Parts Certificate, a manufacturer's standard "spec locking" is activated, but in agreement with the customer transmitters are not blocked and then the locking should be on by manufacturer of conversion devices.

Local buttons are protected by a screw display cover, which is sealed. When "spec MID locking" is done can change only certain parameters of the transmitters, ie: HART transmitter address and the time constant, and can be made additional entries identifying the transmitter associated with its place of installation. The proceedings relating to the sealing set out in p. 8.



The pressure transmitter, as a part of the gas conversion of type 2, in accordance with the requirements of the MID Directive must be protected against unauthorized manipulation by its producer or manufacturer of the gas volume converter. Sealing of the transmitters is done by its manufacturer or, by agreement with the customer, they may not be sealed, then sealing should be made by manufacturer of gas volume conversion.

### 6.2. Measurement error (according to EN12405-1:2005+A2:2010) in relation to the measured value:

- at the rated temperature range (-25 ÷ 55°C) **≤ 0.5%**
- at reference conditions **≤ 0.2%**

### 6.3. Long term stability / 5 years

**≤ 0.5%**

The manufacturer recommends a vertical mount transmitter APC-2000ALW during the pressure measurements in MID applications.

## 7. APC-2000ALW in MID application. Electronic display

Electronic indicating device (display), built-in the APC-2000ALW transmitters, are not controlled metrologically and as such cannot be used for clearing in accordance with EN12405-1:2005+A2:2010.

## 8. APC-2000ALW in MID application. Protection against unauthorized manipulation

**8.1. Blocking by the transmitters manufacturer.** Access to the local configuration buttons and to the transmitter internal components is blocked by the sealing of the display cover and a measuring head locking screw to the housing of the transmitter. The transmitter rated plates are made of materials self-destructive during detachment, or alternative used metal rated plates have one of the screws sealed to the casing. Access "spec MID locking" protects against unauthorized interference to transmitters from a HART system. APC-2000ALW series transmitter manufacturer is using with a plastic seal in its MID realization. Change of the "spec MID locking" status ("ON" or "OFF") is possible after removing of the manufacturer sealing from the local buttons side cover only.

**8.2. Blocking by the gas volume conversion manufacturer.** Turn on the "spec MID locking" with local buttons using local menu of transmitter (p.10.2.5.2 DTR.APC.APR.ALW.03(ENG), MID\_WP – "ON"). Put the seals of the gas volume conversion producer on the cover, screw of a sensor head and a label if it is metal made. Places of seals application is shown by the arrows at Fig. 1c. Seal should be made in accordance with the documentation of gas volume conversions in the place/country their use.

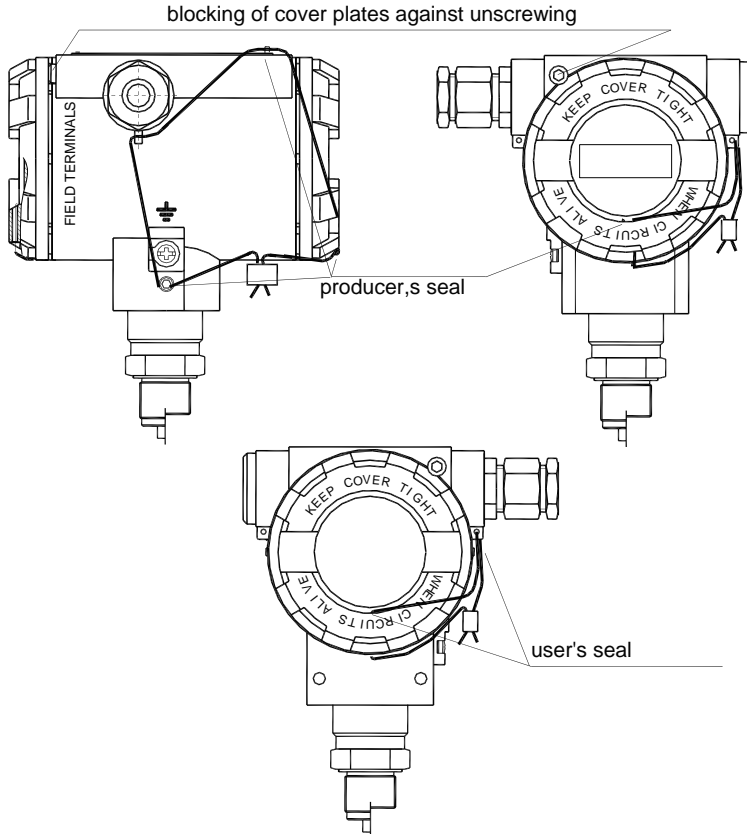

Fig 1c. APC-2000ALW in MID application. Sealed up transmitter.

## 9. APC-2000ALW in MID application. Alarms

Pressure transmitters in MID version alarm exceeding of the limits of measuring ranges (lower and upper) by flag in the output signal HART, and information, respectively "o u E r" or "u n d E r" in place of the first process variable on a transmitter display. Other alarms work as at p.10.3 this User Manual DTR.APC.APR.ALW.03(ENG).

## 10. Verify of the pressure transmitter in its workplace

To verify the correct functioning of the transmitter at its workplace should be used a HART system diagnostic tool implemented to transmitter. For this purpose is need:

- converter HART / RS-232 or other for example HART/USB/Bluetooth Converter;
- PC with Windows XP or higher, with at least 512 MB of RAM;
- Report 2 APLISENS software.

A computer with a converter must be connected to the transmitter as shown in Figure 2a or 2c for the load resistance  $R_o < 240 \Omega$ , see User's Manual DTR.APC.APR.ALW.03(ENG) p.16. Drawings. After starting Report 2 program read data from the transmitter. Installation parameters and current parameters of the transmitter are recorded in the tabs of the Report 2. And so in:

- **Identification** tab - read the identity data of the transmitter;
- **Basic parameters** tab - check the measuring range, pressure unit and time constant;
- **Process Variables** tab - check the current parameters of the transmitter measuring;
- **Write protection** tab - check the setting of current lock before entries;
- **Transmitter Status** tab - check the current status of the transmitter, its analog and digital outputs status with the marked exceeded errors of measuring range, or errors of particular blocks of the transmitter if they would existed.



Transmitter verify in the workplace should make a worker who is trained in the handling of measuring electrical installations in explosive environments.

## 11. APC-2000ALW in MID application. Repair, calibration

Transmitters repair should be performed by the manufacturer, or the manufacturer's authorized repair shops. The procedures of handling after transmitters repairs should be in accordance to the provisions of the country where transmitters are operating.



## VI. FEATURES, INSTALLATION AND MAINTENANCE OF TRANSMITTERS

### 1. INTRODUCTION

1.1. This Manual is intended for users of **APC-2000ALW** smart pressure transmitters, **APR-2000ALW**, **APR-2200ALW**, **APR-2000GALW**, **APR-2000ALW/L**, **APR-2200ALW/L** smart differential pressure transmitters, **APR-2000YALW** smart level probe, **APC-2000ALW/L** smart level transmitter and their intrinsic-safety versions, containing the data and guidelines necessary to understand the functioning of the transmitters and how to operate them. It includes essential recommendations concerning installation and use, as well as emergency procedures. The parameters and information specified for transmitters identified here as **APC...**, **APR...** also apply to transmitters: **APC-2000ALW**, **APR-2000ALW**, **APR-2200ALW**, **APR-2000ALW/L**, **APR-2200ALW/L**, **APR-2000GALW**, **APR-2000YALW**, **APC-2000ALW/L** and their explosion-proof versions, as well as all the variations differing by the type of the process terminals. Information on the transmitter sizes and the method of installation apply to both, all versions of transmitters.

1.2. Technical data for the diaphragm seals and for the **APC...** and **APR...** transmitters are contained in the catalogue cards "**DIAPHRAGM SEALS**".

1.3. The transmitters comply with the requirements of EU directives as shown on the plate and with the relevant Declaration of Conformity.

1.4. Additional data for **APC-2000ALW**, **APR-2000ALW**, **APR-2200ALW**, **APR-2000GALW** and **APR-2000YALW** transmitters in intrinsic-safety Ex versions in accordance with ATEX directive is contained in the appendix designed to **DTR.APC.APR.ALW.03(ENG) Appendix Exi.ATEX** and in flame-proof Exd versions in the appendix designed to **DTR.APC.APR.ALW.03(ENG) Appendix Exd.ATEX**.



During installation and use of the transmitters in Ex or Exd version in accordance with ATEX directive, reference should be made to **DTR.APC.APR.ALW.03(ENG)** in conjunction with **Appendix Exi.ATEX** or **Appendix Exd.ATEX**.

1.5. Additional data for **APC-2000ALW**, **APR-2000ALW**, **APR-2200ALW**, **APR-2000GALW** and **APR-2000YALW** transmitters in intrinsic-safety Ex versions in accordance with IECEx certificate is contained in the appendix designed to **DTR.APC.APR.ALW.03(ENG) Appendix Exi.IECEx** and in flame-proof Exd versions in the appendix designed to **DTR.APC.APR.ALW.03(ENG) Appendix Exd.IECEx**.

During installation and use of the transmitters in Ex or Exd version in accordance with IECEx certificate, reference should be made to **DTR.APC.APR.ALW.03(ENG)** in conjunction with **Appendix Exi.IECEx** or **Appendix Exd.IECEx**.

1.6. The pressure transmitters: **APC-2000ALW**, **APR-2000ALW** in realization for sea uses are complied with Det Norske Veritas (DNV) Rules for Classification of Ships, High Speed & Light Craft and Det Norske Veritas' Offshore Standards. Certificate **No. A-13385** for application in following Location Classes: Temperature **D**, Humidity: **B**, Vibrations: **B**, EMC: **B**, Enclosure: **C**.

1.7. The **APC...**, **APR...** transmitters are also made in a version which complies with the PED Pressure Directive, meet the requirements for category IV, and then carry additional markings as in p. 4.3.

1.8. Essential data relating to installation of **APC-2000ALW** transmitters in accordance with MID Directive contains **MID Appendix**.

### 2. USER MATERIALS

Transmitters are delivered in single and/or multiple packs.

Together with the transmitter are delivered:

- Product certificate (which is also as the warranty card);
- Declaration of conformity (on request);
- Copy of certificate (on request);
- User's Manual numbered: **DTR.APC.APR.ALW.03(ENG)**.

Items b), c), d) are available on [www.aplisens.pl](http://www.aplisens.pl)

### 3. APPLICATIONS AND MAIN FEATURES

3.1. The **APC...** smart pressure transmitters are designed to measure gauge pressure, vacuum pressure and absolute pressure of gases, vapours and liquids (including corrosive substances).

Differential pressure transmitters type **APR...** are used to measure liquid levels in closed tanks, with static pressure up to 25MPa, or 32MPa for special versions and to measure differential pressure across constrictions such as filters and orifices.



3.2. The transmitters may be fitted with a range of types of process connectors, which enables them to be used in a variety of conditions such as thick or highly reactive media, high and low temperatures, etc.

3.3. **APC...**, **APR...** transmitters generate a 4...20mA output signal and a digital HART signal in a two-wire system (current loop). The use of smart electronics enables regulation of the zero point, the measurement range, damping, radical conversion characteristic and other functions using an Aplisens KAP communicator or from a PC using a HART/RS232 or HART/USB/Bluetooth Converter and Aplisens "Raport 2" configuration software.

## 4. IDENTIFYING MARKS. ORDERING PROCEDURE

4.1. Every transmitter carries a rating plate containing at least the following information: CE mark, manufacturer name, transmitter type, serial number, pressure range, static pressure limit, output signal, power supply voltage. Version types and the method of specifying the desired product are described in the current "Information Cards" and the Catalogue.

4.2. **APC...**, **APR...** transmitters in Ex version or Exd version has additional markings as described in **DTR.APC.APR.ALW.03(ENG) Appendix Exi or Exd**.



4.3. The rating plates of **APC...**, **APR...** transmitters in versions compliant with the PED pressure directive contain the notified unit number 0062 next to the CE mark, as well as the designations of certificates number: ( H1).

4.4. **APC...**, **APR...** transmitters in realization for sea uses have additional information about signs environmental classes and DNV Certificate **No. A-13385**.



4.5. The rating plates of **APC-2000ALW** transmitters in **MID** version contain MID Part Certificate Number and information about realization according to EN 12405-1.

## 5. TECHNICAL DATA

### 5.1. **APC...**, **APR...** *Common parameters*

#### 5.1.1. **APC...**, **APR...** *Electrical parameters*

Versions of the transmitter	Power supply	Notes
normal	12 ÷ 55V DC	
special	10 ÷ 55V DC	
intrinsically Safe (Exi,SC)	13.5* ÷ 28V DC	see Appendix Exi.ATEX
intrinsically Safe (Exi)	10.5 ÷ 28V DC	see Appendix Exi.ATEX or Exi.IECEx
explosion proof (Exd)	13.5* ÷ 45V DC	see Appendix Exd.ATEX or Exd.IECEx
MID (Exi)	13.5* ÷ 28V DC	see Appendix MID
MID (Exd)	13.5* ÷ 45V DC	see Appendix MID

\*) Backlight setting of indicates increases the minimum supply voltage for all versions by 3V;

Output signal

4÷20mA + HART rev.5.1

Communication with the transmitter to check its configuration parameters is carried out via HART transmission protocol and signal of 4÷20mA. For this purpose: KAP-03, KAP-03Ex communicator, HART/RS232 converter or HART/USB/Bluetooth Converter (APLISENS) or another converter, PC computer and Raport 2 programme can be used.

Resistance for communication (HART)

min 240Ω

Load resistance

$$R_o[\Omega] = \frac{U_{sup}[V] - 12V^{**}}{0.0225A}$$

The maximum length of the connection cable

1500m

Value of the minimum supply voltage transmitters in standard version should be calculated from:



$$U_{supply \text{ min.}} = 12^{**} + 0.0225 \cdot R_o [V]$$

$R_o [\Omega]$  is a total resistance of the measuring line (current loop)

\*) For other versions of transmitters insert lower supply voltage specified in the table above.

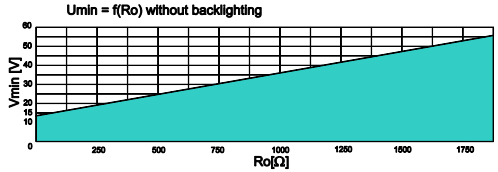
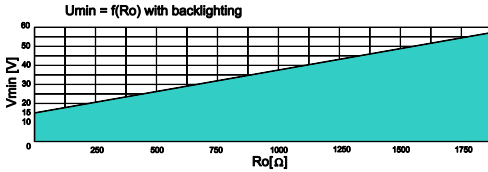

Safe working area for normal transmitter (grid) upper colour area.

Output updating time 500ms  
 Additional electronic damping 0...60s

**5.1.2. APC..., APR... Construction materials**

- Diaphragm seal for APC... Stainless steel 1.4404/1.4435(316L)(PED version) or Hastelloy C276
- Diaphragm seal for APR... Stainless steel 1.4404/1.4435(316L)(PED version) or Hastelloy C276
- Sensing module Stainless steel 1.4404 (316L)
- Liquid filling the interior the sensing module Silicone oil, chemically inactive liquid for measurement of oxygen uses.
- Connectors for APC... Stainless steel 1.4404 (316L) or Hastelloy C276 only for P, GP, CM30x2
- C-type vented covers and connectors for APR... Stainless steel 1.4404 (316L)
- Electronics casing High pressure cast of aluminium alloy, lacquered with chemical -resistant oxide enamel, colour yellow (RAL 1003) or 1.4401 (316)

Materials for APC... APR... transmitters with diaphragm seals are described in Diaphragm Seals Manual.

**5.1.3. Enclosure ingress protection**

IP 66,67 according to EN 60529  
 IP 65 according to EN 60529 with PD connector

**5.1.4. Response time on pressure stroke**

In response to the pressure stroke measured by the transmitter - full change (100%) of the transmitter output current is carried out over a period of one to a maximum of two values of processing time. The value of transmitter response time can be set in the Raport 2 programme using the slider on the tab Specific parameters -> Configuration.

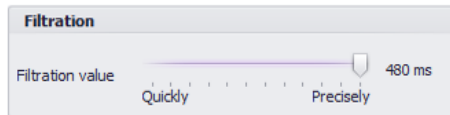

**5.1.5. Accuracy depending on the set range**

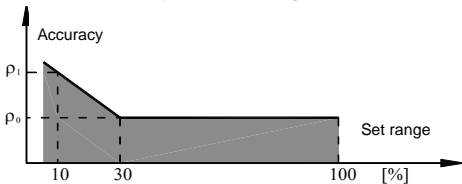

$\rho_0$  – error for nominal measuring range (0...100%FSO)  
 $\rho_1$  - error for range (0...10%FSO)  
 $\rho_1 = 2 \times \rho_0$

## 5.2. APC-2000ALW Measurement ranges and metrological parameters

### 5.2.1. APC..., Measurement ranges

N°	Nominal measuring range (FSO)	Minimum set range	Rangeability	Overpressure limit (without hysteresis)
1.	0...1000bar (0...100MPa)	10bar (1MPa)	100:1	1200bar (120MPa)
2.	0...300bar (0...30MPa)	3bar (300kPa)	100:1	450bar (45MPa)
3.	0...160bar (0...16MPa)	1.6bar (160kPa)	100:1	450bar (45MPa)
4.	0...70bar (0...7MPa)	0.7bar (70kPa)	100:1	140bar (14MPa)
5.	0...25bar (0...2.5MPa)	0.25bar (25kPa)	100:1	50bar (5MPa)
6.	0...7bar (0...0.7MPa)	0.07bar (7kPa)	100:1	14bar (1.4MPa)
7.	-1...7bar (-100...700kPa)	0.07bar (7kPa)	114:1	14bar (1.4MPa)
8.	-1...1.5bar (-100...150kPa)	0.12bar (12kPa)	20:1	4bar (400kPa)
9.	0...2bar (0...200kPa)	100mbar (10kPa)	20:1	4bar (400kPa)
10.	0...1bar (0...100kPa)	50mbar (5kPa)	20:1	2bar (200kPa)
11.	-0.5...0.5bar (-50...50kPa)	50mbar (5kPa)	20:1	2bar (200kPa)
12.	0...0.25bar (0...25kPa)	25mbar (2.5kPa)	10:1	1bar (100kPa)
13.	-100...100mbar (-10...10kPa)	20mbar (2kPa)	10:1	1bar (100kPa)
14.	-15...70mbar* (-1.5...7kPa)	5mbar (0.5kPa)	17:1	0.5bar (50kPa)
15.	-25...25mbar** (-2.5...2.5kPa)	2mbar (0.2kPa)	25:1	1bar (100kPa)
16.	-7...7mbar*** (-0.7...0.7kPa)	1mbar (0.1kPa)	14:1	1bar (100kPa)
17.	0...1.3bar abs (0...130kPa abs)	100mbar abs(10kPa abs)	13:1	2bar (200kPa)
18.	0...7bar abs (0...7MPa abs)	100mbar abs(10kPa abs)	70:1	14bar (1.4MPa)
19.	0...25bar abs (0...2.5MPa abs)	0.25bar abs (25kPa abs)	100:1	50bar (5MPa)
20.	0...70bar abs (0...7MPa abs)	0.7bar abs (70kPa abs)	100:1	140bar (14MPa)

\*) Only for transmitters without diaphragm seal, not available in Exd version.

\*\*) Transmitters available only in HS version.

\*\*) Overpressure limit can be different for version according to PED norm No. 97/23/EC.

### 5.2.2. APC... Permitted environmental conditions

Operating temperature range  $-40^{\circ} \div 85^{\circ}\text{C}$  (for PED version in accordance with p.5.2.4)

 Operating temperature range for intrinsic-safe versions in accordance with Appendix Exi.ATEX or Appendix Exi.IECEx.

 Operating temperature range for flame-proof versions in accordance with Appendix Exd.ATEX or Appendix Exd.IECEx.

Operating temperature range for MID versions in accordance with Appendix MID.

Medium temperature range  $-40^{\circ} \div 120^{\circ}\text{C}$  – for direct measurement, for PED version in accordance with p. 5.2.4. over  $120^{\circ}\text{C}$  measurement with a transmission tube or diaphragm seal using

Thermal compensation range  $-25^{\circ} \div 80^{\circ}\text{C}$ , ( $-40^{\circ} \div 80^{\circ}\text{C}$  for special version)

Relative humidity max 98% with condensation

For transmitters with diaphragm seals permissible temperature and corrosive properties of the medium depend on the type of separators, see **DTR.SEPARATORS**.

### 5.2.3. APC..., Metrological parameters

Accuracy  $\leq \pm 0.075\%$  for the calibrated range (0.1% for range 16)

Special version  $\leq \pm 0.05\%$  of the calibrated range

Long term stability  $\leq$  accuracy / 3 years (for the nominal measuring range) or  $\leq 2 \times$  accuracy / 5 years (for the nominal measuring range)

HS version  $\leq$  accuracy for 6 years

Error due to supply voltage changes  $\max \pm 0.002\%(\text{FSO})/1\text{V}$

Thermal error  $< \pm 0.05\%(\text{FSO})/10^{\circ}\text{C}$

$\max \pm 0.1\% \text{ FSO}/10^{\circ}\text{C}$  for n°13, 14, 16 ranges

Thermal error for the whole thermal compensation range  $\max \pm 0.25\%(\text{FSO})$

$(\max \pm 0.4\% (\text{FSO})/10^{\circ}\text{C}$  for n°13, 14, 16 ranges

### 5.2.4. APC... Metrological Parameters according to PED version

APC... transmitters, in the PED Pressure Directive versions, are produced with a measurement range in the interval from -100 kPa to 40MPa gage, or from 0 to 40MPa absolute, with the overpressure up to 44 MPa. APC... pressure transmitters with the S-Mazut seal pressure connection, assembled with the PED version can be produced within the range -100 kPa to 10 MPa gage, or within the 0-10 MPa absolute, and the overpressure up to 11 MPa. Temperature limits:

- for options according to H1D+H1 Modules:  $-40^{\circ} \div 100^{\circ}\text{C}$  ( $-40 \div 150^{\circ}\text{C}$  with S-Mazut connector);

### 5.2.5. APC..., Pressure Connectors

- M-type connector with M20x1.5 thread – see Figure 6a, available for PED version;
- P-type connector with M20x1.5 thread – see Figure 7a, available for PED version;
- CM30x2-type connector with flush diaphragm – see Figure 8a;
- G1/2 -type connector with G1/2" thread – see Figure 9a, available for PED version;
- GP -type connector with G1/2" thread, available for PED version;
- CG1-type connector with G1" thread and flush diaphragm – see Figure 9e, available for PED version;
- RM-type connector with M20x1.5 thread and radiator;
- RP-type connector with M20x1.5 thread and radiator;
- G1/4-type connector with G1/4 thread, available for PED version;
- 1/2"NPT -type connector with 1/2"NPT tread, available for PED version;
- R1/2-type connector with R1/2 tread, available for PED version;
- CG1/2-type connector with G1/2 tread and flush diaphragm, available for PED version;
- other connection types by arrangement.

## 5.3. APR-2000ALW, APR-2000ALW/L, APR-2200ALW, APR-2200ALW/L Measurement ranges and metrological parameters

### 5.3.1. APR-2000ALW, APR-2000ALW/L, Measurement ranges

N <sup>o</sup>	Nominal measuring range (FSO)	Minimum set range	Rangeability	Overpressure limit	Static pressure limit
1	0...70bar (0...7MPa)	7bar (700kPa)	10:1	C-type: 250, 320, 420bar (250bar for PED version) (P-type: 40bar)	
2	0...16bar (0...1.6MPa)	1.6bar (160kPa)	10:1		
3	0...2.5bar (0...250kPa)	0.2bar (20kPa)	12.5:1		
4	0...1bar* (0...100kPa)	50mbar (5kPa)	20:1		
5	0...0.25bar* (0...25kPa)	10mbar (1kPa)	25:1		
6	-0.5...0.5bar* (-50...50kPa)	0.1bar (10kPa)	10:1		
7	-100...100mbar* (-10...10kPa)	10mbar (1kPa)	20:1	C-type: 200bar(10bar for PED version) (P-type: 40bar)	
8	-5...70mbar* (-0.5...7kPa)	4mbar (0.4kPa)	18:1		
9	-25...25mbar* (-2.5...2.5kPa)	2mbar (0.2kPa)	25:1		
10	-7...7mbar** (-0.7...0.7kPa)	1mbar (0.1kPa)	14:1		

\*) available also in HS version.....\*\*) available only in HS version

### 5.3.2. APR-2200ALW, APR-2200ALW/L, Measurement ranges

Nominal range (FSO)	Minimum set range	Vertical spacing of diaphragm seals.	Maximum configurable range dependent on the actual vertical spacing of diaphragm seals (m)	Static pressure limit
-160...160 mbar	0.1 mH <sub>2</sub> O	≤ 1.7m	[1.6+(vertical spacing of sealsx0.94)]mH <sub>2</sub> O	40bar
-0.5...0.5 bar	0.5 mH <sub>2</sub> O	≤ 6m	[5+(vertical spacing of sealsx1.04)]mH <sub>2</sub> O	40bar
-1.6...2 bar	1.5 mH <sub>2</sub> O	≤ 15m	[20+(vertical spacing of sealsx1.04)]mH <sub>2</sub> O	40bar
-1.6...16 bar	1bar	≤ 15m	16bar	40bar

The maximum vertical diaphragm seal spacing shown in the table applies to level measurement, ensuring that it is possible to set the zero point of the transmitter when the tank is empty.



For measurements of density or phase boundaries (in the sugar and chemical industries and in refineries) the vertical spacing of the diaphragm seals can be larger.

### 5.3.3. APR... Permitted environmental conditions

Operating temperature range	-25° ÷ 85°C (for PED version in accordance with p.5.3.5)
Special version	-40° ÷ 85°C



Operating temperature range for intrinsic-safe versions in accordance with Appendix Exi.ATEX or Appendix Exi.IECEx.

Operating temperature range for flame-proof versions in accordance with Appendix Exd.ATEX or Appendix Exd.IECEx.

Medium temperature range	-25° ÷ 120°C – for direct measurement, for PED version in accordance with p. 5.3.5 over 120°C measurement with a transmission tube or diaphragm seal using
Thermal compensation range	-25° ÷ 80°C
Relative humidity	max 98% with condensation

For transmitters with diaphragm seals permissible temperature and corrosive properties of the medium depend on the type of separators, see **DTR.SEPARATORS**.

### 5.3.4. APR-2000ALW, APR-2000ALW/L, APR-2200ALW, APR-2200ALW/L, Metrological parameters

Accuracy	≤ ± 0.075% (FSO) of the calibrated range (for the APR-2000ALW) ≤ ± 0.1% (FSO) for range n°10 (for the APR-2000ALW)
Special version	≤ ± 0.05% of the calibrated range (for the APR-2000ALW) ≤ ± 0.1% (FSO) for the APR-2200ALW
Long term stability	≤ accuracy / 3 years or ≤ 2 x accuracy / 5 years
HS version	≤ accuracy for 6 years
Error due to supply voltage changes	± 0.002%(FSO)/1V
Thermal error	≤ ± 0.05%(FSO)/10°C for range n° 1...9 ≤ ± 0.08%(FSO)/10°C for range n° 10 ≤ ± 0.25%(FSO) for the whole compensation range
Special version	≤ ± 0.03%(FSO)/10°C for range n° 1...9 ≤ ± 0.1%(FSO) for the whole compensation range
Zero shift error for static pressure*	± 0.06 % (FSO)/10bar (for range n°1, 2) ± 0.01 % (FSO)/10bar (for range n°3, 4, 5, 6, 7, 9) ± 0.03 % (FSO)/10bar (for range n°8) ± 0.02 % (FSO)/10bar (for range n°10)

Cut-off on radical characteristic curve up to 10% of flow.

\*) Zeroing in static pressure conditions with zero differential pressure eliminates this error.

### 5.3.5. APR... Metrological Parameters according to PED version

APR... transmitters which conform to PED are characterised by a measurement range of between -100kPa and 2.5MPa, static pressure of 25MPa and the overpressure of 27.5MPa.

The permissible operating temperature for option according to:

- H1D+H1 Module is between -25°C and 100°C;

### 5.3.6. APR-2000ALW, APR-2000ALW/L, Pressure Connectors

APR-2000ALW, APR-2000ALW/L – C-type connector to mount together with a valve manifold see Fig.10, available for PED version.

APR-2000ALW, APR-2000ALW/L with single direct diaphragm seal – as in the example (Fig.11) or with other diaphragm seals in accordance with “DIAPHRAGM SEALS” catalogue cards.

### 5.3.7. APR-2200ALW, APR-2200ALW/L, Pressure Connectors - diaphragm seals

see “DIAPHRAGM SEALS” catalogue cards.

## **5.4. APR–2000GALW, Measurement ranges and metrological parameters**

### **5.4.1 APR–2000GALW. Measurement ranges**

N°	Nominal range (FSO)	Minimum set range	Overpressure limit	Static pressure limit
1	0...25mbar (0...2500Pa)	1mbar (100Pa)	1bar	350mbar
2	-2.5...2.5mbar (-250...250Pa)	0.2mbar (20Pa)	350mbar	350mbar
3	-7...7mbar (-700...700Pa)	1mbar (100Pa)	350mbar	350mbar
4	-25...25mbar (-2500...2500Pa)	5mbar (500Pa)	1bar	1bar
5	-100...100mbar (-10...10Pa)	20mbar (2kPa)	1bar	1bar

### **5.4.2. APR–2000GALW Permitted environmental conditions**

Operating temperature range -30° ÷ 85°C



Operating temperature range for intrinsic-safe versions in accordance with Appendix Exi.ATEX or Appendix Exi.IECEx.

Thermal compensation range -10° ÷ 70°C

Relative humidity max 98% with condensation

### **5.4.3. APR–2000GALW. Metrological parameters.**

Nominal range	0...25mbar	-2.5...2.5mbar	-7...7mbar	-25...25mbar	-100...100mbar
Accuracy	± 0.075 %	± 0.25 %	± 0.1 %	± 0.1 %	± 0.075 %
Thermal error	± 0.1 % (FSO)/ 10°C, max ± 0.4 % (FSO) for the whole thermal compensation range				
Additional electronic damping	0...30 s				

### **5.4.4. APR–2000GALW. Construction materials**

M20x1.5/Ø6x1 adapter

brass

Valve manifold

1.4404 (316L)

Valve manifold adapter

1.4404 (316L)

¼ NPT connector

brass, 1.4404 (316L) or galvanized St3S carbon steel

(Other materials as given in 5.1.2 for APR...)

### **5.4.5. APR–2000GALW. Pressure Connectors**

- The terminals fit adapted to ø 6x1 plastic tubes,
- Valve manifold adapter or ¼ NPT connector (see p. 8.3 and Fig.18).

## **5.5. APR–2000YALW. Measurement ranges and metrological parameters**

### **5.5.1. APR–2000YALW. Measurement ranges.**

N°	1	2
Nominal range	0... – 6000 mmH <sub>2</sub> O	0... – 1600 mmH <sub>2</sub> O
Minimum set range	600 mmH <sub>2</sub> O	160 mmH <sub>2</sub> O
Static pressure limit	40 bar	

### **5.5.2. APR–2000YALW Permitted environmental conditions**

Operating conditions as in section 5.3.3 for APR...

### **5.5.3. APR–2000YALW. Metrological parameters.**

Nominal range N°	1	2
Accuracy for basic range	± 0.16 %	± 0.2 %
Accuracy for minimum range	± 0.5 %	± 0.6 %
temperature error	0.4 % for temperatures -25°...+80°C	
Zero shift error from static pressure *	0.08 % / 10bar	0.1 % / 10bar

\* zeroing in static pressure conditions with zero differential pressure eliminates this error;

Medium density range – up to 1.1 g/cm<sup>3</sup> – (standard version)

– over 1.1 g/cm<sup>3</sup> – (special version by arrangement with Aplisens)

## **5.6. APC–2000ALW/L.... Measurement ranges and metrological parameters**

### **5.6.1. APC–2000ALW/L....level transmitter. Measurement ranges.**

N°	1	2	3
Nominal range (FSO)	0...20m H <sub>2</sub> O	0...10m H <sub>2</sub> O	0...2.5m H <sub>2</sub> O
Minimum set range	2m H <sub>2</sub> O	1m H <sub>2</sub> O	0.5m H <sub>2</sub> O
Possibility of zero shift	0...18m H <sub>2</sub> O	0...9m H <sub>2</sub> O	0...2m H <sub>2</sub> O
Overpressure limit	0...200m H <sub>2</sub> O	0...100m H <sub>2</sub> O	0...25m H <sub>2</sub> O

### **5.6.2. APC–2000ALW/L....level transmitter. Permitted environmental conditions**

Operating conditions as in section 5.2.2 for APC...

### **5.6.3. APC–2000ALW/L....level transmitter. Metrological parameters.**

Accuracy	± 0.16% (FSO) for the APC-2000ALW nominal range
Long term stability	≤ accuracy / 2 years
Error due to supply voltage changes	± 0.002%(FSO)/1V
Thermal error	± 0.1%(FSO)/10°C
	± 0.4%(FSO) in the whole compensation range.

### **5.6.4. APC–2000ALW/L.... level transmitter. Pressure Connectors**

- SG-25 sensor;
- SG-25S sensor;
- SG-25C sensor;
- SG-25S-tytan sensor;
- SG-16 sensor;

### **5.6.5. APC–2000ALW/L.... pressure, level transmitter.**

Pressure range	see p. 5.2.1
Metrological	see p. 5.2.3
Pressure connectors	see p. 5.2.5



## **5.7. APC ... APR ... Environmental parameters**

### **5.7.1. Electromagnetic Compatibility (EMC), Immunity**

Criterion according to EN 61326-1,2

#### *Electrostatic Discharge (ESD):*

EN 61000-4-2

level 3,

contact ±6kV

air ±8kV

Criterion A

#### *Conducted Radio Frequency:*

EN 61000-4-6

0.15... 80MHz, 10V

Criterion A

#### *Radiated Electromagnetic Field:*

EN 61000-4-3

80... 2 000MHz – 10V/m

... 2 700MHz – 1V/m

Criterion A

#### *Electrical Fast Transient (Burst):*

EN 61000-4-4

± 1kV

Criterion A

#### *Electrical Slow Transient (Surge):*

EN 61000-4-5

± 1kV

Criterion B

### **5.7.2. Electromagnetic Compatibility, emission**

Criterion according to CISPR16-1, CISPR 16-2, class B

#### *Radiated Emission:*

Distance from antenna: 3m

limits quasi-peak:

0.15 ... 30MHz, 80-52dB $\mu$ V/m;

30 ... 2000MHz, <54dB $\mu$ V/m

#### *Conducted Emission:*

limits quasi-peak:

0.01 ... 0.150MHz, 96-50dB $\mu$ V/m;

0.150 ... 0.350MHz, 60-50dB $\mu$ V/m;

0.35 ... 30MHz, <50dB $\mu$ V/m

### **5.7.3. Climatic Immunity**

#### *Temperature:*

EN 60068-2-1, EN 60068-2-2

hot: T = 55°C, RH = max 55%

cold: T = -25°C,

#### *Damp Heat Cycle:*

EN 60068-2-30,

(T = 55°C, RH = min 95%, 24h)x2

#### *Salt Mist:*

5% NaCl, pH 6.5 ... 7.2 at 20°C

T = 40°C, RH = min 93%, 28 days

### **5.7.4. Mechanical Immunity**

#### *Shocks:*

EN 60068-2-27

50g/11ms

#### *Sinusoidal Vibrations:*

EN 60068-2-6, test Fc

do 1.6mm, 2 ... 25Hz

do 4g for 25 ... 100Hz

### **5.7.5. Electrical Isolation**

>100 M $\Omega$  @750V DC Ex

>100 M $\Omega$  @110V DC normal, marine, PED

### **5.7.6. Insulation Strength**

550V AC or 750V DC, 1min

Ex, marine

75VAC or 110V DC, 1min

normal, PED

### **5.7.7. Enclosure Ingress Protection**

EN 60529

IP 66,67

## 6. CONSTRUCTION

### **6.1. Principle of measurement. Electronic system construction**

The electrical signal from the sensor which is proportional to the pressure is sent to a digital analog input and converted to a digital signal. The digital signal is transmitted through optoelectronic galvanic barrier to conditioning module. The main plate microcontroller reads measured values and using internal algorithms calculates the exact value of pressure and temperature. The calculated value of the process variable is displayed on the integrated LCD screen, which can be configured as needed. The digital value of the measured pressure signal is converted to an analogue 4 - 20 mA signal. A built-in modem BELL 202 and HART rev5.1 communication stack enables communication with the transmitter via a converter HART/RS232 attached to a PC and software, or via communicator. The electrical output of transmitter is equipped with a suppression filter and surge protective elements. The block circuit of transmitter is presented at Fig 1. The **APC...**, **APR...** transmitters monitor the work of their hardware resources and the correctness of calculations, and inform about mistakes by displaying a message on the LCD screen, and exposing the alarm current in the loop (depending on configuration). Sensor electronics is galvanically separated from the measuring line. This allows reduce a susceptibility of measurement to interference and increased safety in intrinsically safe and flameproof applications.

### **6.2. Enclosure of transmitters**

Enclosures of **APC...**, **APR ...** transmitters are made of die-cast aluminium alloy or stainless steel and consist of a body and two screwed covers (display and electrical connection), one of which is equipped with a glass window. The enclosure provides two holes on the cable entries with thread M20x1.5 or ½ NPT (the unused hole is sealed with stopper). The housing consists of two chambers separated by an electrical culvert. Housing is equipped with ground terminals: internal and external. The basic units of transmitter are: measuring sensor, in which pressure signal is converted into electric signal, and electronic units, transforming signal from measuring sensor into unified output signal.

### **6.3. Main electronics plate with display**

Main plate electronics with display is placed in the casing of polycarbonate. It is placed in bigger from two chambers where is possibility to change of display position by 345 with 15° increments to required position (in "Version SC" rotation the display is possible by 180°, in ±90°) (see Fig 4). In second chamber is placed a connecting board with protective devices and EMC filter.

### **6.4 Measuring head**

The measuring head is a measuring unit equipped with a silicon membrane sensor. The sensor is placed in a silicone oil-filled space enclosed, on one side of the culvert with the leads insulated in glass on the other side of the separating membrane which separates the sensor from the medium (**APR...** transmitters have a two separated membranes). Measuring heads are equipped with process connectors as at Fig. 6a, 7a and 8a or other. **APR...** transmitters measured head has two process connectors type P or C connector (Fig. 10) for assembly on manifold. Measuring head of **APR-2000GALW** is intended to low pressures of gases with overpressure to 100kPa (or 35kPa). This transmitter in standard version (economic) is equipped in the process connectors adjusted to elastic pipes  $\varnothing 6 \times 1$ , and in industrial versions in adapters as Figure 18.

### **6.5. Separators**

For pressure measurement of viscous, chemically reactive or hot process mediums, the transmitter may be additionally fitted with various types of diaphragm seal.

The diaphragm seal transmits the process pressure via an inert fluid fill between the diaphragm of the seal and the diaphragm of the transmitter. When remote diaphragm seals are fitted, the pressure between the diaphragm seal and the transmitter is via a filled capillary. The seal's construction is dependent on the process medium properties and the application operating conditions.

**APR-2000YALW** smart level probe is equipped in diaphragm seal and flange to fixing on tank.

## 7. PLACE OF INSTALLATION

### 7.1. General recommendations

**7.1.1.** The smart pressure transmitter and differential pressure transmitter can be installed both indoors and outdoors. It is recommended that transmitters intended for outdoor use be placed in a box or under cover.

**7.1.2.** The place of installation should be chosen in such a way as to allow access to the device and to protect it from mechanical damage. In planning the installation of the transmitter and configuration of the impulse lines, attention should be paid to the following requirements:

- The impulse lines should be as short as possible, with a sufficiently large cross-section, and free of sharp bends, in order to prevent blockages;
- Where the medium is a gas, the transmitters should be installed above the measuring point, so that condensation flows down towards the site of the pressure measurement; where the medium is a liquid or where a protective liquid is used, the transmitters should be installed below the place where the pressure measurement is taken;
- The impulse lines should be inclined at a gradient of at least 10cm/m;
- The levels of filling liquid in the impulse lines should be equal or kept constant difference;
- The configuration of the impulse lines and the valve connection system should be chosen with regard to the measurement conditions and to requirements such as the need to reset the transmitters in position and the need for access to the impulse lines during water or gas removal and flushing.



**7.1.3. Where there is a risk of damage to the transmitter thorough impact (which can result in extreme cases with the transmitter being separated from the connecting pipework thus permitting leakage of medium), appropriate means of protection should be applied for obvious safety reasons and to avoid the possibility of sparking caused by being struck. If the transmitter cannot be suitably protected then an alternative mounting location should be sought.**



**7.1.4.** Attention should also be paid to possible installation faults which may lead to measurement errors, such as connections which are not tight, sediment blockage in lines which are too narrow, gas bubbles in a liquid line or liquid column in a gas line etc.

### 7.2. Low Ambient Temperature



**When the solidification point of the liquid whose pressure is being measured is higher than the ambient temperature, steps should be taken to protect the measurement apparatus from freezing effects such as medium expansion.**

This is particularly important in the case open-air installations.

Protection is obtained by filling the impulse lines with a mixture of ethylene glycol and water, or another liquid whose solidification point does not exceed the ambient temperature. Thermal insulation can protect the transmitter casing and lines only from brief exposure to low temperatures. Where the temperature is very low, the transmitter and impulse lines should be heated.

### 7.3. High Medium Temperature

The **APC...**, **APR...** transmitters may be used to measure media with temperatures of up to 120°C (PED version see p 5.2.4, 5.3.5). To protect the sensing module from temperatures higher than 120°C, long impulse lines are used to disperse the heat and to lower the temperature of the sensing module.

Where it is not possible to use impulse lines of the required length, **APC...**, **APR...** transmitters with remote diaphragm seals should be used (see “**DIAPHRAGM SEALS**” catalogue cards).



**Data as per Appendix Exi.ATEX / Appendix Exi.IECEx apply for the Ex version and Appendix Exd.ATEX / Appendix Exd.IECEx apply for the Exd version.**

## **7.4. Mechanical Vibration shocks. Corrosive Media**

**7.4.1.** Transmitters should correctly work with vibrations with amplitudes to 1.6 mm and accelerations to 4g. If strong vibrations are carried via the pressure line and disturb of measuring, use should be made of elastic pulse lines or transmitters with a remote diaphragm seal.

**7.4.2.** Transmitters should not be installed in places where the diaphragm, made of 1.4404/1.4435 (316L) steel, would be subject to corrosion by the medium being measured. If possible, transmitters with diaphragms made of Hastelloy C276 should be used, or other means of protection applied (e.g. in the form of a separating liquid) or transmitters with diaphragm seals adapted for measuring aggressive mediums according to “**DIAPHRAGM SEALS**” catalogue cards should be used).



## **8. INSTALLATION AND MECHANICAL CONNECTIONS**

The **APC...**, **APR...** transmitters can operate in any position.

When installed on an object with a high-temperature medium, it is advantageous to mount the transmitter in a horizontal position or downwards, in such a way that the transmitter is kept away from the rising hot air.



For the small measurement ranges, the reading can be affected by the transmitter position, and by the impulse lines configuration, or the way in which they are filled with liquid. This error can be corrected using the zero-setting function.

### **8.1. APC... Installation and connections**

**8.1.1.** The **APC...** transmitters can be mounted directly on the rigid impulse lines.

For used connectors as in Figures 5a, 6a and 7a, it is recommended that connection sockets be used as shown in Figure 6b, 7b, 8b or 8c. It is recommended that sockets labelled “Socket CG1” and „Socket CG1/2” Fig. 9 are used for CG1 and CG1/2 connections, respectively.

Besides, there are adapters for standard DIN50, (DIN40, DIN25, Clamp2”, Clamp1.5”, Clamp1”) type connections provided for readouts carried out in aseptic conditions using transmitters with CM30x2 connection.

There are gaskets provided for every transmitter with P, CM30x2, CG1, CG1/2 and GP type connections.

The gasket material is selected based on the pressure value, temperature and the type of the medium.

**8.1.2.** If the pressure is applied via a flexible plastic tube, the transmitter should be mounted on a support with Red Ø6-M reduction.

The types of the impulse tubes (Fig.25) are to be selected depending on the pressure measured value and the medium temperature.

**8.1.3.** Tighten the transmitter in the socket with a torque suitable for the type of the gasket used and the pressure measured.

**8.1.4.** The **APC...** transmitter can be installed using a universal “AL” holder allowing to mount the transmitter in any position on the support or a horizontal or vertical pipe Ø35... Ø65 (Fig. 17).

### **8.2. APR... Installation and connections**

**8.2.1.** The **APR ...** transmitters can be mounted directly on rigid impulse lines.

To connect the transmitter basic versions, with two M20 x 1.5 connectors (P-type connector), can use (for example) straight connecting elements with C type nuts. If elastic impulse lines are used, the transmitter should be additionally fastened to a pipe, panel or supporting construction.

**8.2.2.** The **APR-2000ALW**, **APR-2000ALW/L** and **APR-2200ALW**, **APR-2200ALW/L** can be installed using the ø25 Fastener (Fig.12) on an ø25 pipe or on a flat surface using an angle bracket.

**8.2.3.** The **APR-2000ALW**, **APR-2000ALW/L** with connecting cover (C-type connector) (Fig.10) are designed for installation on 3-valve or 5-valve manifolds to a 2” pipe or to a flat surface using “C-2” holder (Fig.13, Fig.14).

### **8.3. APR-2000GALW. Installation and connections**

**8.3.1.** The “economy” version of the **APR-2000GALW** transmitter can be mounted on a wall, panel or other stable construction, using a clamp with Ø9 holes (Fig.18). The transmitter is fitted with connectors which fit to an Ø6x1 elastic impulse tube. When the measuring impulse is transmitted via a metal terminal with M20x1.5 connector, an adapter is used between the M20 x 1.5 threads and the Ø6x1 terminal.

**Transmitters should be installed in a vertical position.** The way of impulse line leading should enable the vapour flowing towards the pipeline. Where there is a significant difference between the height at which the transmitter is mounted and the height of the impulse source, particularly if the measurement range is small, the reading may fluctuate depending on the temperature difference between the impulse lines. This effect can be reduced by ensuring that the impulse lines run side by side.

**8.3.2.** The **APR-2000GALW** transmitter can also be fitted with an adapter (Fig.18) creating a C-type connector, designed for installation on a 3-valve or 5-valve manifold. Aplisens can also supply ready transmitters mounted on valves.

#### **8.4. APR-2000 YALW. Installation and connections**

The **APR-2000YALW** level probes installed in places where liquid levels are measured in closed tanks, with access to medium from top of tank as Fig.19 and 10.2.9. Level probes should be installed in a vertical position.

#### **8.5. APC-2000ALW/L.... Installation and connections**

**APC-2000ALW/L....** installed in places where liquid level is measurement: in wells, tanks, reservoirs, etc.

The transmitter sensor is immersed in measured medium. The sensor can be hung on the power cable by using a Aplisens SG handle , but especially in the case of long cables, or if there are opportunities of hooking protruding elements when the cable is pulling up, it is recommended that the sensor suspended on a steel rope using the sensor lug. If the sensor would be in the flow or turbulence of medium, should be assembled in the casing pipe for example PVC made.

 From sensor SG-25S remove the protective plate before it's placing into medium.  
During the installation the sensor should be protected from mechanical shocks  
Sensor with cable with additional Teflon shield should be hung on steel rope or on a cable (no fasten by Teflon shield).

**Pressure may be transmitted to the installed device only after checking that it has a measurement range which properly corresponds to the value of the measured pressure, that gaskets have been properly selected and fitted, and the connectors have been properly screwed tight.**

 **Attempts to undo the screws or fixing connector pipes on a transmitter under pressure may cause the medium to leak and create hazards for the personnel.**

**When disassembling the transmitter, it is necessary to disconnect it from the process pressure or bring the pressure to atmospheric level, and to take particular care and precautions in case of media which are highly reactive, caustic, explosive or otherwise hazardous to personnel.  
If necessary, rinse out this part of the system.**

Transmitters with flange diaphragm seals are to be installed on the corresponding counter flanges on the facility.

 It is recommended that the user matches the screw joints material to the pressure, temperature, flange material and seal to ensure tightness of the flange joint in the expected operating conditions.

Screws complying with ISO 261 are to be used for flanges used in the **APC...**, **APR...** transmitters.

Additional data concerning the diaphragm seals are specified in the "**DIAPHRAGM SEALS**" catalogue cards.

## **9. ELECTRICAL CONNECTION**

### **9.1. General recommendations**

**9.1.1.** It is recommended that twisted pair cabling be used for the signal lines. If the transmitter and signal line are subject to a large amount of electromagnetic interference, then shield pair cable should be used. The signal wires should not run alongside network power supply cables or near to large electrically-powered devices.

The devices used together with the transmitters should be resistant to electromagnetic interference from the transmission line in accordance with compatibility requirements. It is also beneficial to use anti-interference filters on the primary side of the transformers, the power supplies used for the transmitters and apparatus used in conjunction with them.

**9.1.2. Wet or rising damp inside transmitter can cause its damage.**

 **When the isolation of the wires in the cable gland is ineffective (for example, when single wires are used) the opening of the gland should be carefully sealed with an elastic sealing compound to obtain IP66 protection. It is useful to form the segment of the signal wire leading to the cable gland into a protective loop to prevent condensation from running down in the direction of the gland.**

## **9.2. Electrical connections for APC..., APR...**

The APC..., APR... transmitters are to be connected as shown in Fig. 2a – 2d.



In APC..., APR... transmitters, a 240Ω resistor is permanently fitted in series in the transmitter's current circuit and blocked up with jumper between <SIGNAL → and <TEST → as shown in Fig.2a and 2b. When the resistance in the current loop is lower than 240Ω it is necessary to jumper disassemble to HART communication.

## **9.3. Protection from excess voltage**

**9.3.1.** The transmitters may be in danger from excess voltage caused by connection faults or atmospheric electrical discharge.

Protection from excess voltage between the wires of the transmission line is provided by TVS diodes installed in all types of transmitter (see the table, column 2).

**9.3.2.** In order to protect against excess voltage between the transmission line and the casing or earth (not prevented by the diodes connected between the transmission wires), additional protection is provided in the form of plasma surge arresters (see the table, column 3).

Also external protective devices may be used, e.g. the UZ-2 Aplsens system, or others. When the transmission lines are long, it is advantageous to use one protective device near the transmitter (or inside it), and another near entry points to other devices used in conjunction with it.

Internal protection of transmitters:

1	2	3
Type of transmitter	Protection between wires (TVS diodes) – nominal voltage	Protection between wires and earth and/or casing – type of protection, nominal voltage
APC..., APR...	68V DC (39V DC for Exi version)	Plasma surge arresters - 230V DC (Not applicable to Exi version).

**9.3.3.** The voltage in the protective elements must not exceed the maximum permitted values given in columns 2 and 3 of the table. Security using surge arresters are used for Exi versions with identification on the rating plate "Version SA" or "Version SC, SA".



The insulation test voltages (500V AC or 750V DC) given in 5.1.1 refer to transmitters plasma surge arresters - such protection is not used in Exi versions of transmitters.

## **9.4. Earthing**

The transmitters are fitted with internal and external earth terminals.

# **10. SETTING AND REGULATION**

APC..., APR... transmitters are factory calibrated to the range stated in the order or to the basic range.

After installation, the transmitter's zero-point may move and require adjustment.

This applies particularly in cases where the measurement range is small, where the impulse lines are filled with a separating liquid or where APC..., APR... transmitters are used with remote diaphragm seals.

## **10.1. Transmitter Range, Basic Range. Definitions**

**10.1.1.** The maximum range of pressure, or differential pressure, which the transmitter can measure, is called the “**basic range**” (for specifications of basic ranges see section 5.2.1, 5.3.1, 5.3.2, 5.4.1, 5.5.1).

The width of the basic range is the difference between the upper and lower limits of the basic range.

The internal characteristic conversion curve for the basic range is coded in the transmitter's memory.

This is the reference curve used when making any adjustments which affect the transmitter's output signal.

**10.1.2.** When the transmitter is in use the term “**set range**” is used. The set range is the range whose lower end-point corresponds to an output current of 4mA and whose upper end-point corresponds to a current of 20mA (or 20mA and 4mA respectively when the conversion curve is inverted).

The set range may cover the whole of the basic range or only a part of it.

The width of the set range is the difference between its upper and lower end-points.

The transmitter may be set to any range within the basic range of pressure values, subject to the restrictions set out in the table in section 5.2.1, 5.3.1, 5.3.2, 5.4.1, and 5.5.1.

## **10.2. Configuration and Calibration**

**10.2.1.** The transmitter has features which enable metrological and identification parameters to be set and altered. The configurable metrological parameters affecting the transmitter's output current include the following:

- a) unit in which the measured pressure is expressed on the display;
- b) upper end-point of the set range;
- c) lower end-point of the set range;
- d) time constant;
- e) type of characteristic curve: linear or radical.

Parameters of an informational nature which cannot be altered include the following:

- f) upper limit of the basic range;
- g) lower limit of the basic range;
- h) minimum range.

**10.2.2.** Other identification parameters, not affecting the output signal, include: device address, device type code, factory identification code, factory device code, number of preambles (3+20), UCS, TSD, program version, electronics version, flags, serial number, label tag, description tag, date tag, message, record number, sensing module number.

The process of setting the parameters listed in 10.2.1 and 10.2.2 is called "**Configuration**".

**10.2.3.** It is possible to carry out a "**pressure zeroing**" procedure, for example to compensate for measurement deviation caused by a change in position during the transmitter installation.

The transmitter may also be **calibrated**, by taking readings with the input pressure controlled using a standard device. These process and zero-point adjustments are called "**Calibration**".

**10.2.4. Configuration and Calibration** of the transmitter are carried out using an Aplisens KAP communicator, certain HART communicators or a PC with HART/RS232 converter and Aplisens "Raport 2" software.

Together with the "Raport 2" configuration software there is „INTERVAL LINEARIZATION" software supplied to enable the input of 21-point nonlinear functional characteristics to the transmitter.

A description of the functions of the KAP communicator is contained in the KAP Communicator Operating Manual, and information on the HART/RS232 converter can be found on the HART/RS232/01 Converter information sheet.

### **10.2.5. TRANSMITTER CONFIGURATION WITH USING ITS BUTTONS AND LOCAL MENU**

#### **10.2.5.1. Local menu - structure. Local configuration of transmitters.**

If the option of local configuration is active, operator can change transmitter set using buttons being below display. The access to buttons will get after unscrewing the display cover. Then we can also change the display position (see Fig. 4).

If the option of local configuration is active, operator can change transmitter set using buttons being below display. To enter changes at the local set mode, press one of the buttons and hold it's about 4s. If after pressing the button displays the message ERR\_L16, local configuration of the transmitter is switched off. To its switching on is necessary to use KAP 3 Calibrator or PC (see → HART command 132, 133).

The buttons are signed with symbols: [↑] [↓] [■]

After pressing by 4 seconds any of the buttons on the display will appear "**EXIT**".

If you will confirm this message by pressing and holding button [■] by 1 sec, you will leave the local change of the MENU setting. If you do not confirm, you can move in MENU and change interesting you parameters.

Pressing button [↑] moves up in tree's structure MENU.

Pressing button [↓] moves down in tree's structure MENU.

Pressing [■] confirms choice and leads change.

No action in the menu for more than 2 minutes will cause automatically exit from the menu and move to the display of the process variable.

Method of navigate through the commands in the menu structure **APC...**, **APR...** shown below.

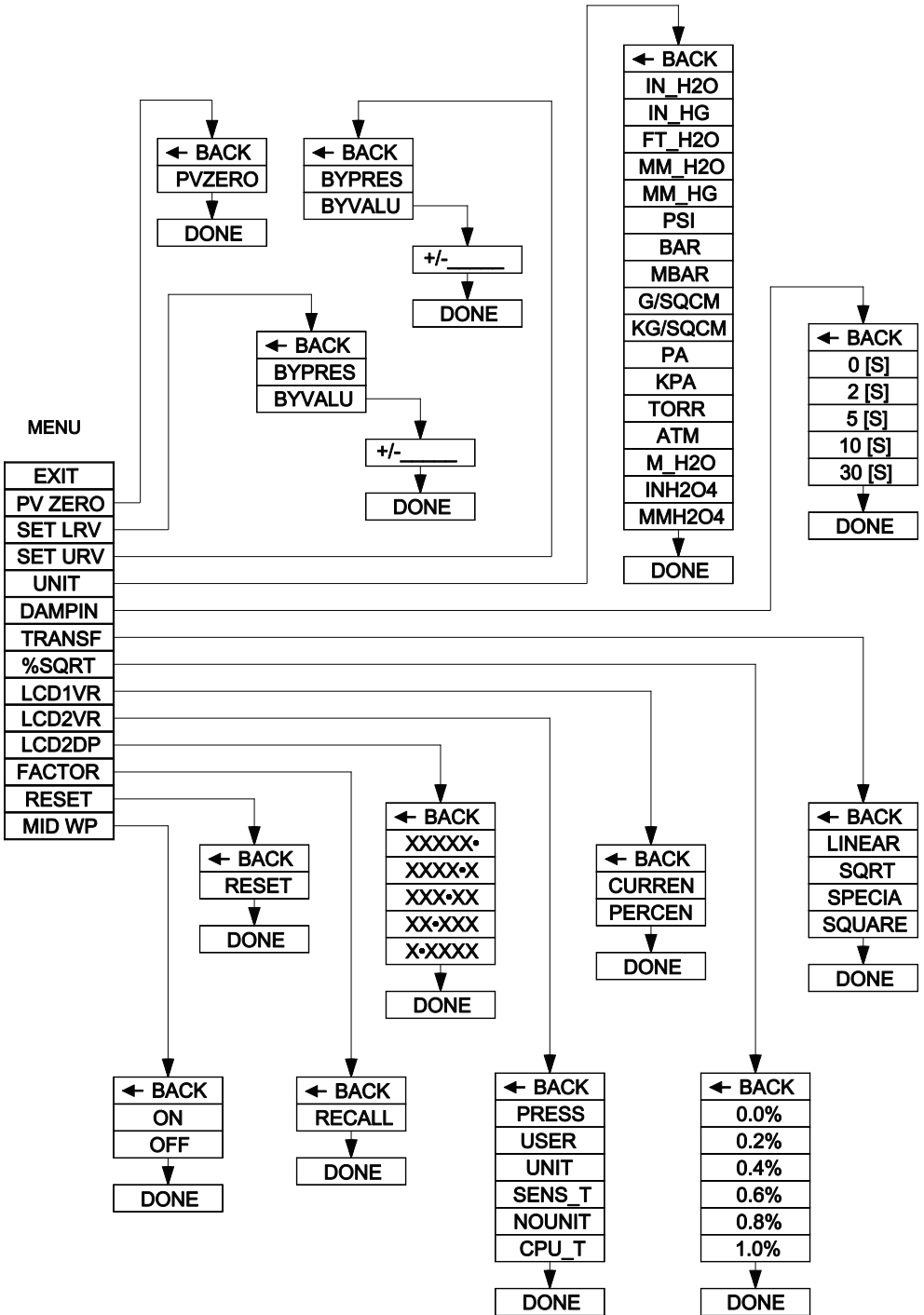



The selected unit should be confirmed by pressing [■].

After approval the parameter transmitter will confirm the party of command by the "DONE" or report the error number. The "← BACK" cause goes up one level.

### Descriptions:

Local Menu	Submenu	Notice
<b>EXIT</b>		Return from the local Menu to the normal operation of the transmitter
<b>PVZERO</b>		Pressure zeroing
<b>SETLRV</b>		Setting the lower range of values set by the done pressure (no change of span)
	<i>BYPRES</i>	Set across set pressure
	<i>BYVALU</i>	Set across inscribing of value (after approval at display the current value will appear before the passage in edit mode)
	+/- _____	Select and confirm sign introduced parameter. Introduce in sequence, digit after digit, 5 digital numbers with point or without point. After confirmation the last 5 digit of the parameter transmitter will confirm the party of command by the "DONE" announcement or the proper number of error will notify. The parameter will be written down in units "UNIT".
<b>SETURV</b>		Set the upper range value by the done pressure
<b>UNIT</b>		Menu process variable units
	<i>IN_H2O</i>	inches of water at a temperature of 68° Fahrenheit
	<i>IN_HG</i>	inches of mercury at a temperature of 68° Fahrenheit
	<i>FT_H2O</i>	Foot of water a temperature of 68° Fahrenheit
	<i>MM_H2O</i>	mm of water at a temperature of 68° Fahrenheit
	<i>MM_HG</i>	mm of mercury at 0°C
	<i>MBAR</i>	millibar
	<i>G/SQCM</i>	grams per square centimetres
	<i>KG/SQCM</i>	kilogram per square centimetres, technical atmosphere
	<i>KPA</i>	kilopascal
	<i>TORR</i>	tor (mm Hg)
	<i>ATM</i>	physical atmosphere
	<i>M_H2O</i>	meter of water at 4°C
	<i>MPA</i>	Megapascal
<i>INH2O4</i>	inch of water at a temperature of 4°C	
<i>MMH2O4</i>	mm of water at 4°C	
<b>DAMPIN</b>		set of the solid temporary suppression of the process variable
<b>TRANSF</b>		set of the current output form
	<i>LINEAR</i>	linear
	<i>SQRT</i>	square root
	<i>SPECIA</i>	user's special
	<i>SQUARE</i>	square
<b>%SQRT</b>		Square root characteristic cut-of point setting
<b>LCD1VR</b>		Assigning a process variable to LCD1
	<i>CURREN</i>	On LCD1 will displayed current value in current loop in [mA]
	<i>PERCEN</i>	The percent value output signal will displayed on LCD1- controlling in%
<b>LCD2VR</b>		Assigning a process variable to LCD2
	<i>PRESS</i>	The pressure value will displayed on LCD2
	<i>USER</i>	The user's units will be displayed on LCD2. Scaling of the user range and record of the user units can be made using a computer or communicator, see → HART command No. 244.245.
	<i>SENS_T</i>	The current temperature of pressure sensor will displayed on LCD2
	<i>CPU_T</i>	The current temperature of the transmitter CPU will displayed on LCD2 - in °C

<b>LCD2DP</b>		Set the decimal point position on LCD2. In a situation where the value provided to display on the display LCD2 cannot be displayed properly due to the position of the decimal point, this is indicated by displaying the four flashing dots ••••. In this case, you must enter to the local menu setting and move the decimal point respectively to the right.
<b>FACTOR</b>		Back to factory settings (removing of current and pressure calibrations)
<b>RESET</b>		Reboot your transmitter
<b>MID_WP</b>		Blocking records / change the parameters associated with transmitter metrology
	<i>ON</i>	Switch on blocking
	<i>OFF</i>	Switch of blocking

### 10.2.5.2. Local Menu, error reports.

During executing in Local Menu some functions, LCD2 announcement can be displayed on the screen.

The error displaying evidences about no realization of command of Local Menu.

The shortened description of errors announcements is showed below.

<b>ERR_L07</b>	[in_write_protected_mode] Error will ensue out when we try to change setting in Local Menu, but transmitter is protected before recording. To make the change of setting with Local Menu using, transmitter has to have the included service of Local Menu as well as switched off protection before record. These parameters modification is possible by using KAP -03 communicator, "Raport 2" program or software using library EDDL. <ul style="list-style-type: none"> <li>• default setting:  Local Menu service                      switched on  protection before record               switched off</li> </ul>
<b>ERR_L09</b>	[applied_process_too_high] Error will ensue out when given parameter (pressure) will be too high. Zeroing or the range setting verifying is necessary.
<b>ERR_L10</b>	[applied_process_too_low] Error will ensue out when given parameter (pressure) will be too low. Zeroing or the range setting verifying is necessary.
<b>ERR_L14</b>	[span_too_small] Error will ensue out when in result of setting range executing change the width of the range will be smaller than admissible.
<b>ERR_L16</b>	[acces_restricted] Error will ensue out when the service of Local Menu is switched off, and the user tries to call out the Menu Local service. You should switch on the service of Local Menu with the KAP-03 communicator, "Raport 2" program, or software using library EDDL. Warning! ERR_L16 announcement can be displayed as well by zeroing attempt of the absolute transmitter.
<b>WNG_L14</b>	[WARNING! New Lower Range Value Pushed !] Error will ensue out when the end of range set (the URV) change will cause the change of the range set beginning (LRV).

### 10.2.6. View local LCD display

Changes of the display options in local MENU are possible using buttons, or remote way using communicator, or the PC software. If it is necessary the display switching off is also possible. The display switching of function is possible with using communicator or PC software only.

The APC..., APR... transmitter display exterior is as bellow.

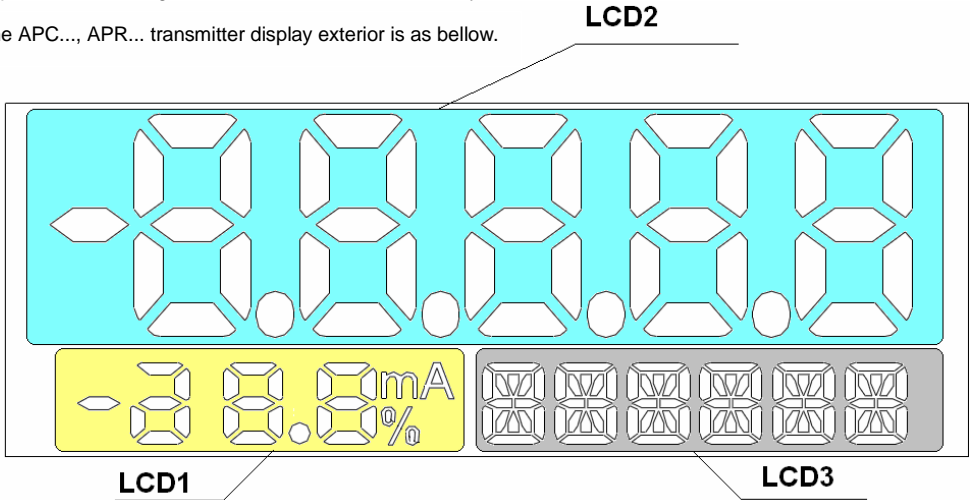

There 3 main displays are visible:

- **LCD1** – the current or guidance percent preset range display. In accordance with display configuration the current value in 4-20 mA current loop, or percent guidance preset range is possible to display.
- **LCD2** – the measured pressure digital value display; the calibrated pressure value according to user's unit's display; the process variable units, or user's units, or pressure sensor or CPU temperature; the MENU announcement and other information or warning announcement display. In the case the digital pressure value or the calibrated pressure value display, the sign „-“ can be visible before displayed value. The decimal point position is possible to set in local MENU or remotely. The pressure unit or user's unit can be displayed. The transmitter makes possible rescale on the user's individual the pressure value. To make this is necessary with using communicator or PC software write the corresponding to beginning and to end values of setting range as well as write the own unit name. After activating user's mode the rescale value will be visible on display.
- **LCD3** – information display. During normal operation is designed for continuous display of the base unit or the user units. In case of errors in the transmitter's work, it displays an error number. In manual mode, the local change settings menu displays options of selecting the setting. It also displays errors related to the implementation of commands in the local menu of the settings change.

**Display backlighting** - Local display is equipped in backlight. In "Version SC" it is possible to switching on and switching off display backlighting via jumper on electronic board as required. How to handle display backlight is shown in Figure 5. Figure 4 shows how to change the display position by rotation.

#### Warning!



**Exceeding the basic transmitter measuring range over 50% range in the up or down is indicated by " o V E r " or " u n d e r " in the display LCD2. Such situation is encountered most often when overloaded a difference pressure transmitter, created when the large static pressure compared to the pressure range will blockage or a leak in one of the capillaries.**



**After configuration it is important to protect the transducers using command HART [247]. During work transmitter should be safe prior to entries. This prevents accidental or intentional changes configurational data. The protection function is accessible in KAP03 communicator, "Raport 2" software, as well as, in applying DD or DMT programs libraries.**

### 10.2.7. Remote configuration

Remote configuration is possible with KAP-XX communicator or PC software. Measuring circuit should be in accordance with the Fig. 2.

## 10.2.8. Configuration of the APR-2200ALW transmitters to measure the level, density of liquid and phase boundary

To simplify the mathematical operations we introduce the density coefficient of the medium  $X\rho$ .

$$X\rho = \frac{\rho_{\text{medium}} [\text{g/cm}^3]}{\rho_{\text{water at 4}^\circ\text{C}} [\text{g/cm}^3]}$$

Since the density of water at 4°C is 1 g/cm<sup>3</sup>, the **density coefficient  $X\rho$  is numerically equal to the density of the medium expressed in g/cm<sup>3</sup>**. To determine the hydrostatic pressure of a column of liquid in mm H<sub>2</sub>O, it is sufficient to multiply the height of the column  $h$  [mm] by the density coefficient of the liquid  $X\rho$ . Since it is easy to determine the hydrostatic pressure in mm H<sub>2</sub>O and the transmitter can be configured in those units, in the descriptions of measurement methods given below we will make use of pressures expressed in mm H<sub>2</sub>O and the density coefficient  $X\rho$ .

### Configuration of the APR-2200ALW transmitters to measure the level of liquid in a tank.

#### The measurement task:

To convert a variation in the level of a liquid with density  $\rho = 0.87 \text{ g/cm}^3$  between 0 and  $h_{\text{max}}$  to a variation in the output signal from 4 to 20 mA.

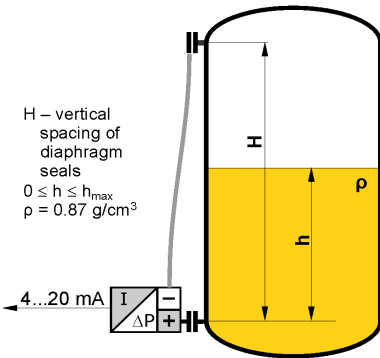

1. Install the transmitter in its working position on an empty tank.
2. Make the electrical connections of the transmitter, providing for the ability to use HART communication.
3. Connect the KAP-03 communicator, identify the transmitter and select the "configuration" function.

4. On the configuration menu select the "Reranging" procedure.
5. On the "Reranging" menu:
  - a) change the units of measurement to mm H<sub>2</sub>O at 4°C;
  - b) enter the values for the start ( $X\rho \times h_{\text{min}}$  [mm]) and end ( $X\rho \times h_{\text{max}}$  [mm]) of the measurement range, namely 0 and ( $0.87 h_{\text{max}}$  [mm]) respectively;
  - c) to compensate for the hydrostatic pressure of the manometric fluid, the start of the measurement range should be set using regulated pressure; when subject to the action of only the manometric fluid (empty tank) the transmitter will shift the start and end-points of the range, compensating for the value of that pressure.

When the transmitter has been configured in this way it is ready to be used to carry out the given measurement task.

If it is not possible to empty the tank to configure the transmitter, the hydrostatic pressure of the manometric fluid should be calculated by multiplying the vertical spacing of the diaphragm seals by the density coefficient of the oil in the capillaries. This pressure should be taken into account when entering the values for the start and end of the range:

Start [mm H<sub>2</sub>O] =  $-H$  [mm]  $\times X\rho_{\text{oil}}$

End [mm H<sub>2</sub>O] =  
 $= h_{\text{max}}$  [mm]  $\times X\rho_{\text{measured liquid}} - H$  [mm]  $\times X\rho_{\text{oil}}$

$\rho_{\text{oil}}$  for DC-550 oil is equal to 1.068 g/cm<sup>3</sup>  
 $\rho_{\text{oil}}$  for AK-20 oil is equal to 0.945 g/cm<sup>3</sup>

### Configuration of the APR-2200ALW transmitters to measure density of liquids.

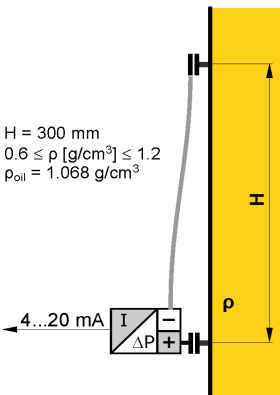

#### The measurement task:

To convert a variation in liquid density from  $\rho_{\text{min}} = 0.6 \text{ g/cm}^3$  to  $\rho_{\text{max}} = 1.2 \text{ g/cm}^3$  to a variation in the output signal from 4 to 20 mA, with the vertical spacing of the diaphragm seals equal to  $H = 3000 \text{ mm}$ . The sealing system is filled with DC-550 oil with density  $\rho_{\text{oil}} = 1.068 \text{ g/cm}^3$ .

1. Calculate the value of the start of the range as follows:  
 $H_{[\text{mm}]} \times (X\rho_{\text{min}} - X\rho_{\text{oil}}) =$   
 $= 3000 \times (0.6 - 1.068) = -1404 \text{ [mm H}_2\text{O]}$
2. Calculate the value of the end of the range as follows:  
 $H_{[\text{mm}]} \times (X\rho_{\text{max}} - X\rho_{\text{oil}}) =$   
 $= 3000 \times (1.2 - 1.068) = 396 \text{ [mm H}_2\text{O]}$
3. Set the zero point of the transmitter with the diaphragm seals positioned at the same level.
4. Install the transmitter in its working position.
5. Make the electrical connections to the transmitter, providing for the possibility of using HART communication.

6. Connect the KAP-03 communicator, identify the transmitter and select the "configuration" function.
7. On the configuration menu select "Reranging" procedure.
8. On the "Reranging" menu:
  - a) change the measurement units to mm H<sub>2</sub>O at 4°C;
  - b) enter the calculated values for the start (-1404) and end (396) of the range.

When the transmitter has been configured in this way it is ready to be used to carry out the given measurement task.

Note: If it is possible to fill the space between the seals with a liquid whose density corresponds to the start of the measurement range, the start of the range of the transmitter can be set using regulated pressure.

### Measurement of phase boundary

The height of the phase boundary of liquids of different densities is determined by measuring the average density of the medium between the seals.

#### Example:

Calculate the measurement range start and end points for an APR-2200 transmitter configured to measure phase boundary height in the range 0–1000 mm between liquids of density  $\rho_1 = 0.7 \text{ g/cm}^3$  and  $\rho_2 = 1.0 \text{ g/cm}^3$ , where the vertical spacing of the seals  $H = 1600 \text{ mm}$ . The sealing system uses DC-550 oil with a density of  $1.068 \text{ g/cm}^3$ .

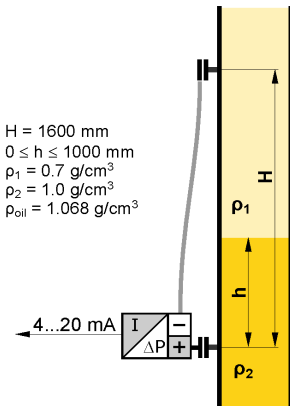

To determine the start of the measurement range, calculate the pressure difference at the transmitter when the tank is filled with the lighter liquid only:

$$1600 \text{ [mm]} \times (0.7 - 1.068) = -588.8 \text{ [mm H}_2\text{O]}$$

To determine the end-point of the range, add the increase in pressure resulting from the appearance of a 1 metre column of the heavier liquid:

$$-588.8 \text{ [mm H}_2\text{O]} + (1.0 - 0.7) \times 1000 \text{ [mm]} = -288.8 \text{ [mm H}_2\text{O]}$$

### Additional remarks

The settings of the transmitter can be adjusted with reference to laboratory results from density measurements carried out on samples of the liquid being measured. This is most often necessary when the measurement takes place in a pipeline segment where the flow velocity of the measured liquid reaches several m/s.

Increasing the vertical spacing of the diaphragm seals widens the range and often improves measurement accuracy.

In planning the spacing of the diaphragm seals, ensure that the pressure difference at the transmitter lies within the basic range.

The maximum vertical spacing of the diaphragm seals ( $H$ ) depends on the transmitter's basic range and the boundary values for the density of the measured liquid ( $\rho_{\min}$ ;  $\rho_{\max}$ ).

If  $\rho_{\min} < \rho_{oil} < \rho_{\max}$ , the seal spacing  $H$  should satisfy the following conditions:

$$H \text{ [mm]} \leq \frac{\text{lower boundary of range [mm H}_2\text{O]}}{X\rho_{\min} - X\rho_{oil}}$$

$$H \text{ [mm]} \leq \frac{\text{upper boundary of range [mm H}_2\text{O]}}{X\rho_{\max} - X\rho_{oil}}$$

#### Example:

Determine the maximum vertical spacing of the seals for the APR-2200 / -10...10 kPa transmitter when measuring the density of liquid between 0.6 and 1.2 g/cm<sup>3</sup>. The sealing system uses AK-20 silicone oil with a density of 0.945 g/cm<sup>3</sup>.

The lower boundary of the range of the transmitter is -10 kPa = -1020 mm H<sub>2</sub>O

$$H \text{ [mm]} \leq \frac{-1020}{0.6 - 0.945} \Rightarrow H \text{ [mm]} \leq \frac{-1020}{-0.345} \Rightarrow$$

$$H \text{ [mm]} \leq 2957$$

The upper boundary of the range of the transmitter is +10 kPa = 1020 mm H<sub>2</sub>O

$$H \text{ [mm]} \leq \frac{1020}{1.2 - 0.945} \Rightarrow H \text{ [mm]} \leq \frac{1020}{0.255} \Rightarrow$$

$$H \text{ [mm]} \leq 4000$$

In the example, both conditions are satisfied when the spacing of the seals is not more than 2957 mm.

### 10.2.9. Configuration of the APR-2000YALW smart level probes

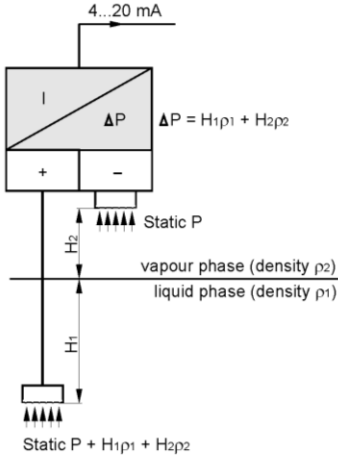

### Principles of operation

Measurement is carried out using an APR-2000 differential pressure transmitter, enabling compensation for static pressure in the tank. The value processed is just the hydrostatic pressure of the medium measured at the level of the diaphragm of the lower seal. This pressure is the sum of the hydrostatic pressures of the liquid and vapour phases of the medium. In most practical measurement situations the density of the vapour phase is negligibly small, and therefore the measured hydrostatic pressure relates only to the height of the liquid phase column and can be taken as representing the level of the surface of the liquid phase. For media where the density of the vapour phase is significant (e.g. propane) the level found by the method described can be treated as the theoretical level of the liquid level obtained by adding the actual liquid phase to the condensed vapour phase.

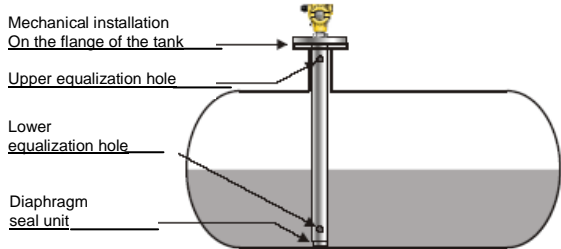

### Configuration example

To convert a rise in the level of liquid with density 0.87 from 0 to 3200 mm to a current change from 4 to 20 mA.

1. Install the transmitter in working position, place the seal at the appropriate height (tank empty).
2. Calculate the width of the measurement range in mm H<sub>2</sub>O (4°C):  $3200 \text{ mm} \times 0.87 \text{ g/cm}^3 = 2784 \text{ mm H}_2\text{O}$ .
3. Using the communicator, set the transmitter to use the units **mm H<sub>2</sub>O at 4°C**.
4. To determine the start of the measurement range, read off via the communicator the hydrostatic pressure produced by the manometric fluid in the capillary (e.g. **-4250 mm H<sub>2</sub>O**).
5. To determine the end-point of the measurement range, add the value **-4250 mm H<sub>2</sub>O** and the width of the measurement range **-4250 mm H<sub>2</sub>O + 2784 mm H<sub>2</sub>O = -1466 mm H<sub>2</sub>O**.
6. Using the communicator enter the calculated start (**-4250 mm H<sub>2</sub>O**) and end-point (**-1466 mm H<sub>2</sub>O**) of the measurement range and send as a block to the transmitter. After receiving these parameters the transmitter will perform measurements as required.

**10.2.10. Configuration of the APR- 2000ALW transmitters for the flow measurements with the orifice plate.**

It is important to proper placement of the transmitter depending on the type of measured medium, otherwise it may negative impact on the measurement.

**Mounting diagram for liquid and steam flow:**

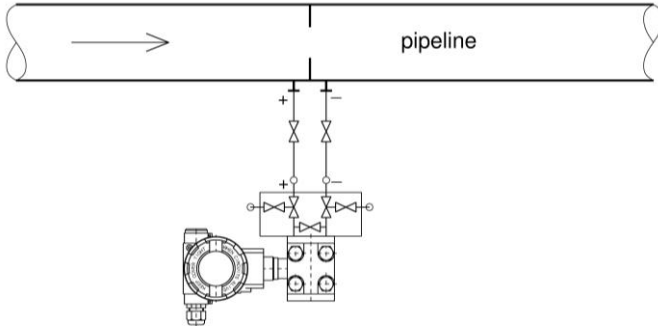

The transmitter should be located below the pipeline. It prevents the accumulation of air bubbles in the connecting line.

**Mounting diagram for gas flow:**

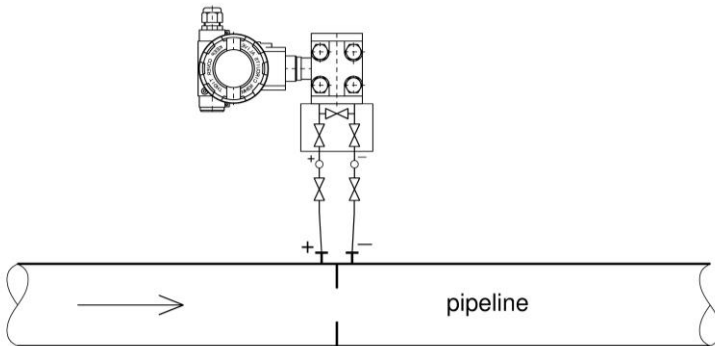

The transmitter should be located above the pipeline. It enables the condensate flow down to the pipeline.

Function described the relationship between mass flow and differential pressure is:

$$Qm = \sqrt{2\rho\Delta p}$$

Function described the relationship between volume flow and differential pressure is:

$$Qv = \sqrt{\frac{2\Delta p}{\rho}}$$

$\rho$  – medium density  
 $\Delta p$  – differential pressure

Orifice flow meters are based on the square root output signal from the differential pressure transmitters.

To archive this function you should:

- Install the APR-2000 ALW transmitter to the flow measurement workstation with orifice;
- Make the transmitter zeroing at the workstation; remotely using computer and Aplisens Raport 2 software or locally with transmitter buttons according to p. 10.2.5 of the Manual;
- Set the square root output transmitter signal and the cutoff point [in % FS]; remotely using computer and Aplisens Raport 2 software according with p. 10.2.4 or locally with transmitter buttons (up to 1% only) according to p. 10.2.5 of the Manual.

For transmitters with software from 1.9 version, the cutoff point setting means, that, when the pressure is increasing from 0 to set cutoff point ( $n\%$ FS), the output signal is zero (4mA), but in the setting cutoff point and above its, the transmitter output signal passes to the square root output for the current transmitter output, and to the linear output for the HART transmitter output. If the pressure on orifice falls below the  $n\%$ FS setting minus 0.2% (hysteresis), the output transmitter signal will switch to zero (4mA). The cutoff operation algorithm on the analog output signal example is shown at the below figure.

#### Description:

I [mA] – analog output signal; loop current [4-20 mA] or A [%];

$n\%$  - cutoff point at square root output transmitter signal;

PV or Z [%] - axis of the process variable in user unit or in percent of the set range;

LRV – Lower Range Value; the lower value of the pressure set range (corresponds to the 4 mA current output signal);

URV – Upper Range Value; the upper value of the pressure set range (corresponds to the 20 mA current output signal).

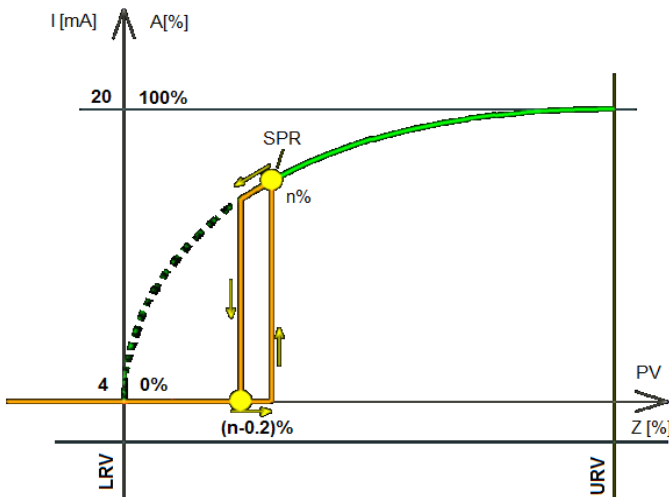

APR-2000ALW transmitter analog output signal with setting cutoff point in  $n\%$ .

#### The device configuration example:

Transmitter configuration parameters

- |               |                     |
|---------------|---------------------|
| - Basic range | 0...100 kPa         |
| - Set range   | 0...50 kPa          |
| - Cutoff      | 5% of the set range |

Assemble the measuring system in accordance with Figure 2 and run Raport2 according to IO.RAPORT2:

- Set the zero of the transmitter – tab page: Basic Commands → Zeroing;
- Set the width of the set range the transmitter to a value of 0 ... 50 kPa - tab page: Common Parameters → Lower Range Value and Upper Range Value
- Set the square root output signal of transmitter – tab page: Common Parameters → Transfer Function;
- Enter 5 in the parameter area inflection point – tab page: Common Parameters → Start point rad;
- Save the data to the transmitter (button: Write Parameters).

The cutoff function will be implemented to 5% of set range with pressure increase and to 4.8% of set range with a pressure decrease



## **10.3. Alarms**

Alarms signal exceeding the limits of the transmitter correct operation or non-functioning some of its components. Menu of **APC...**, **APR...** transmitters contains the following alarms: HART modem error, ADC error (error of A /D converter), EEPROM error, error of the oscillator, DS33 error (check the correctness of floating point calculations). Errors reveal themselves by issuing in the transmitter current line: 22mA (high alarm) or 3,6mA (low alarm), and signalling an error code on the display. Alarm current in the output transmitter line of 3.6 (low) or 22mA (high) can be set using the Raport 2 configuration program, or the currents alarm settings in transmitter should be agreed with the producer. Exceeding of the basic pressure range of over 50% is indicated on the transmitter display by code E0256 and alarm current in the measuring line; exceeding of the measuring ranges in MID pressure transmitters is described in MID Appendix.

## **11. INSPECTIONS AND SPARE PARTS**

### **11.1. Periodic service**

Periodic inspections should be made in accordance with the regulations to which the user is subject. During inspection, the pressure connectors should be checked for loose connections and leaks, the electrical connectors should be checked with regard to tightness and the state of the gaskets, cable glands, and the diaphragm seals should be checked for tarnishing and corrosion.

Check the characteristic conversion curve by following the procedures for "Calibration" and, where appropriate, "Configuration".

### **11.2. Other services**

If the transmitters are installed in a location where they may be exposed to mechanical damage, excess pressure, hydraulic impulses or excess voltage, or the diaphragm may be in danger from sedimentation, crystallization or erosion, inspections should be carried out as required.

**i** Where it is found that the signal in the transmission line is absent or its value is incorrect, a check should be made on the line and its terminal connections.

Check whether the values of the supply voltage and load resistance are correct.

If a communicator is connected to the power supply line of the transmitter, a fault in the line may be indicated by the message "No response" or "Check connection".

If the line is in order, check the operation of the transmitter.

### **11.3. Cleaning the Diaphragm Seal, Overloading Damage**

**11.3.1.** Sediment and dirt which have formed on the diaphragm in the course of operation must not be removed by mechanical means, as this may damage both the diaphragm and the transmitter itself.

The only permitted method is the dissolving of sediment.

**11.3.2.** Sometimes transmitters malfunction due to damage caused by overloading, e.g. in case of:



- **Application of excessive pressure;**
- **Freezing or solidification of the medium;**
- **Action of a hard object, such as a screwdriver, on the diaphragm.**

Usually in such cases the symptoms are such that the output current falls below 4mA or rises above 20mA, and the transmitter fails to respond to input pressure.

### **11.4. Spare parts**

Parts of the transmitter which may be subject to wear or damage and require replacement: cover gasket.

**i** **Other listed parts, due to the specific features and requirements of explosion-protected devices, may be replaced only by the manufacturer or by a firm authorized by the manufacturer.**

## **12. PACKING, STORAGE AND TRANSPORT**

The transmitters should be packed singly or in sets, in such a way as to protect them from damage during transportation.

The transmitters should be stored in multiple packs under cover, in a place free of vapours and reactive substances, with temperature and humidity not exceed the limits specified in p. 5.2.2 for APC... or p. 5.3.3 and 5.4.2 for APR....

Transmitters with uncovered diaphragm or seal connectors, stored without packaging, should have covers to prevent damage to the diaphragm.

During transportation, the transmitters should be packed and secured so as to prevent them from shifting.

Any means of transport may be used, provided direct atmospheric effects are eliminated.

### 13. GUARANTEE

The manufacturer reserves the right to make constructional and technological changes which do not lower the quality of the transmitters

### 14. SCRAPPING, DISPOSAL

Waste or damaged transmitters should be dismantled and disposed of in accordance with Directive (2002/96/EC) on waste electrical and electronic equipment (WEEE) or returned to the manufacturer.

### 15. ADDITIONAL INFORMATION

The manufacturer reserves the right to make constructional and technological changes which do not lower the quality of the transmitters.

#### 15.1. Related documents

- IO.KAP-03.02 – Communicator User's Manual.
- IO.RAPORT 2 – "Raport 2" software and HART/RS232 converter User's Manual.
- DTR.HB.01 – HART/USB/Bluetooth converter User's Manual.
- „INTERVAL LINEARIZATION" software.

### 16. FIGURES

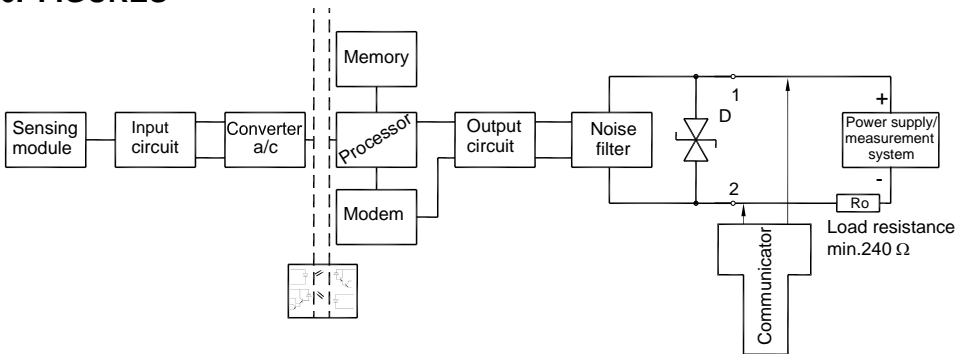

Fig. 1. APC..., APR... transmitters – block diagram.

#### Communicator or converter electrical connections to transmitter measuring lines.



For successful communication with transmitter the resistance in measuring loop, behind connected device to communication, should be higher than 240Ω. If necessary install the additional resistor in the line. The communicator or converter connecting ways to the measuring loop are presented at diagrams. During increasing of resistance in the measure loop at making the good transmission, is necessary to make sure that the tension falls at sum resistances in the loop don't lower minimum tension at transmitter terminals. **(see p.5.1.1)**

**Connection of the APC..., APR... transmitter**

Connect as shown in Fig. 2a. If it is necessary to enable communication with the transmitter, a communicator or converter can also be connected.

Optional connection configurations to communication devices are shown below.

**Communicator or converter connection near to a switch box**

In order to enable communication with a transmitter at a distant location via connection near to a switch box, make sure that the resistance  $R_o$  from the point of connection of the communicator to the power supply source lies within the range of  $240+1100 \Omega$ . If necessary, an additional resistance can be integrated into the line. Connect the communicator or converter as shown in Fig. 2a.

**Fig. 2.** Electrical connections for APC..., APR... transmitters:

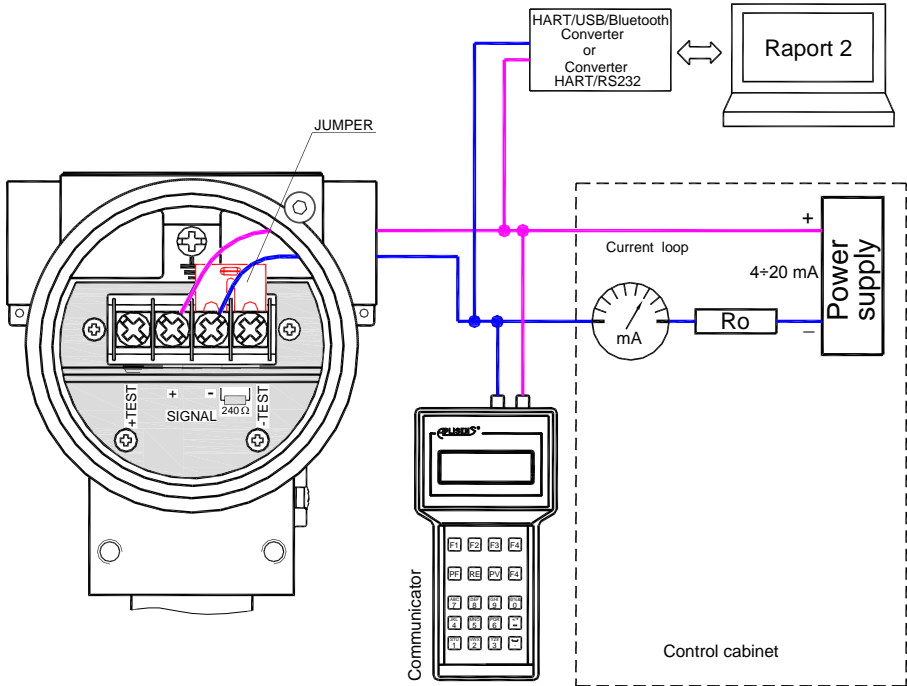

**Fig.2a.** The link of transmitter and communicator or converter to current line by the switch box (in case of the resistance in current loop is higher than  $240\Omega$ ).

**Communicator or converter connection to the transmitter's terminals**

In order to enable local communication by connecting a communicator or converter to the transmitter's terminals, make sure that the resistance  $R_o$  from the transmitter's terminals to the power supply source lies within the range of  $240 \pm 1100 \Omega$ . If so, connect the communicator or converter to the terminals <+> <-> as shown in Fig. 2b.

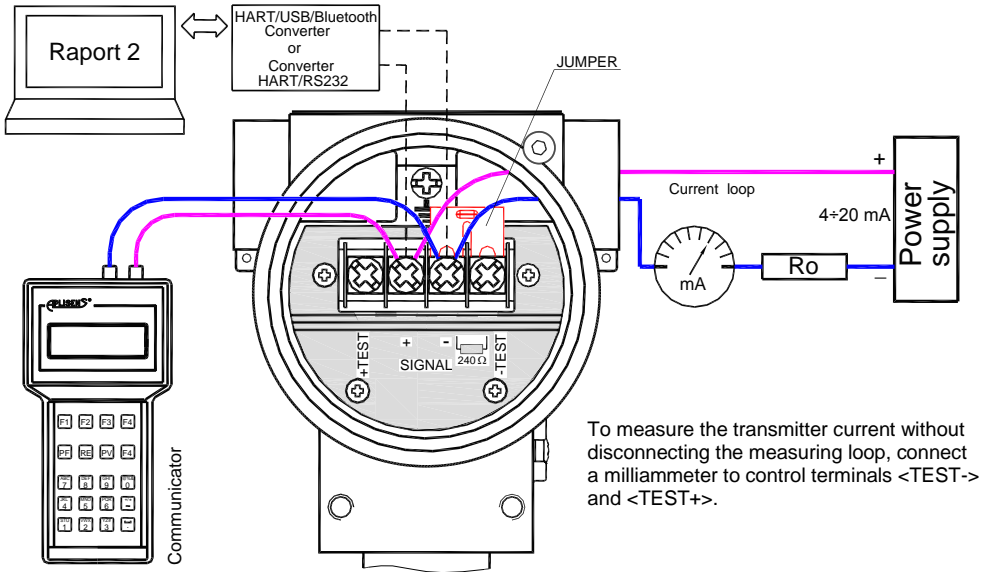

**Fig.2b.** The link of transmitter and communicator or converter to <SIGNAL+> <SIGNAL-> transmitter terminals in case of the resistance in current loop is **higher than 240Ω**.

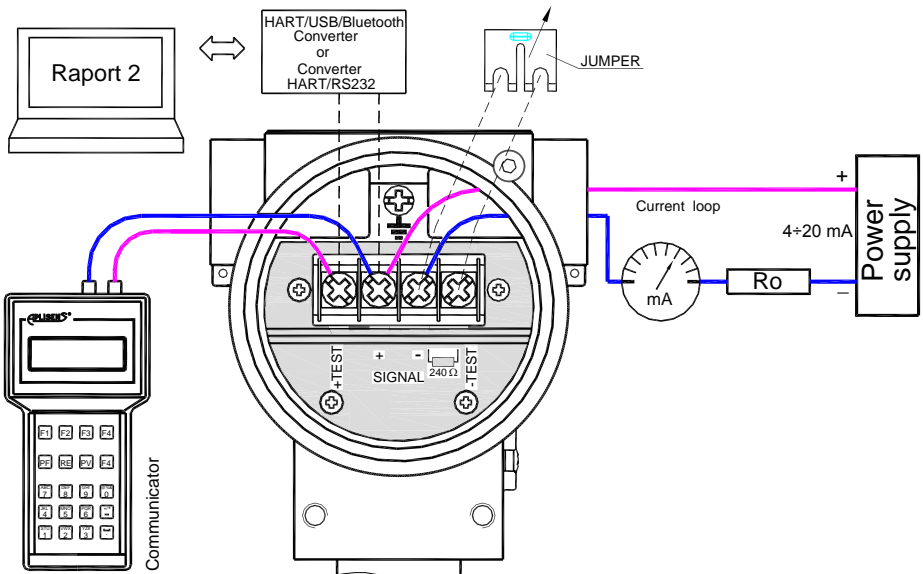

**Fig.2c.** The link of transmitter and communicator or converter to <SIGNAL+> <TEST-> transmitter terminals in case of the resistance in current loop is **smaller than 240Ω**.

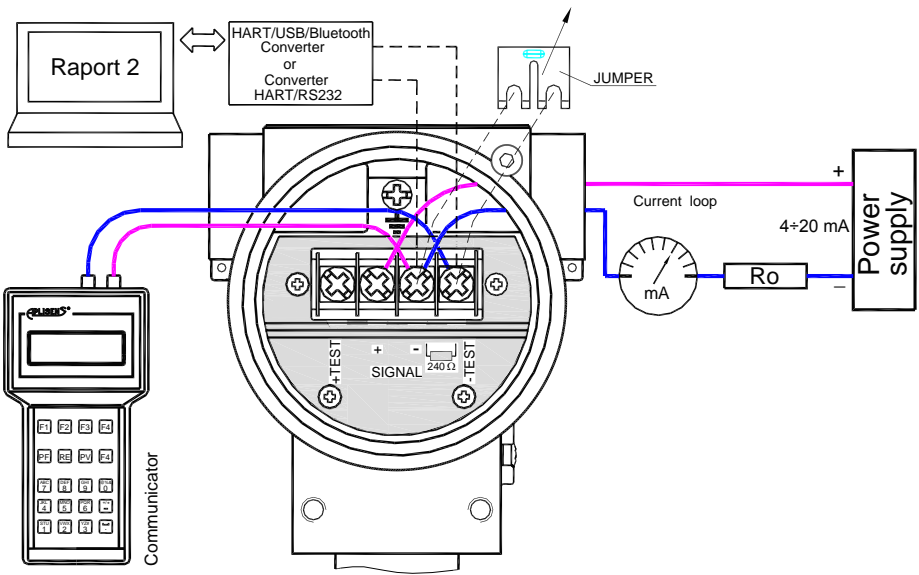

**Fig.2d.** The link of transmitter and communicator or converter to <SIGNAL+> <SIGNAL-> transmitter terminals in case of the resistance in current loop is smaller than 240Ω.



If  $R_o$  in current loop is lower than  $240\Omega$  is necessary to connect  $240\Omega$  resistor to current loop by remove jumper from <SIGNAL-> and <TEST-> terminals. After communication jumper should come back at its place.

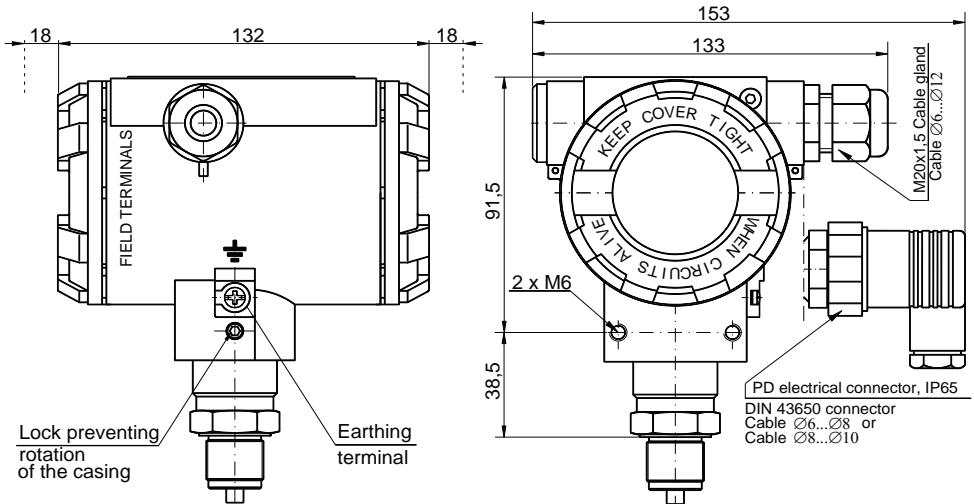

**Fig. 3.** APC-2000ALW smart pressure transmitter.

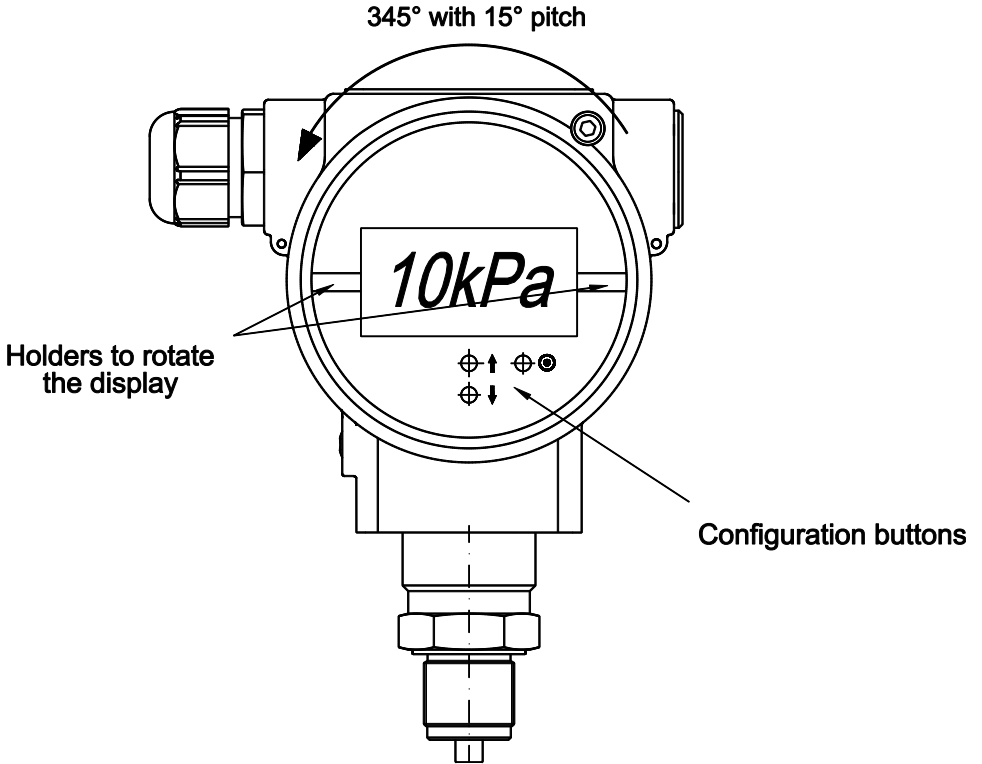

Fig. 4. APC..., APR.... display rotation possibility, configuration buttons.

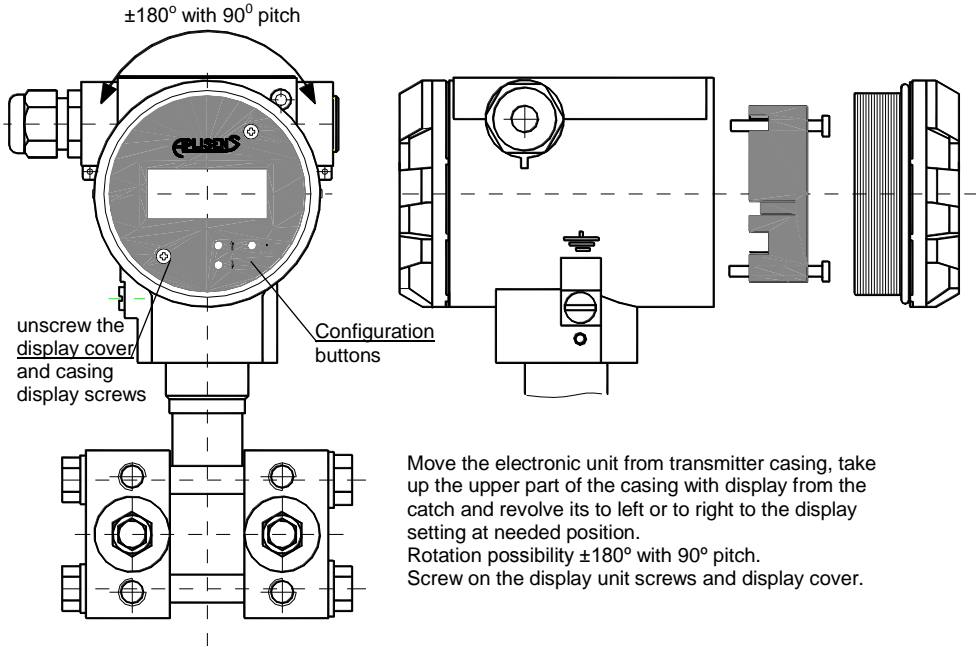

Fig. 4a. "Version SC" for APC..., APR.... display rotation possibility, configuration buttons.



Jumper in radial position (as at photo) –back lighting off; jumper in circular position –back lighting on.

Fig. 5. Back lighting jumper view at transmitter electric board (unit display back side).

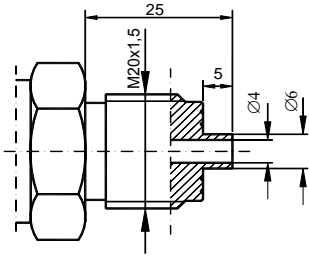

Fig.6a. M-type connector with M20x1.5 thread

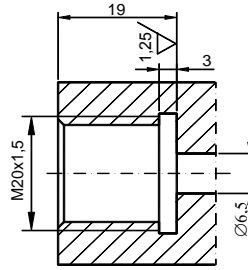

Fig.6b. Socket for M-type connector

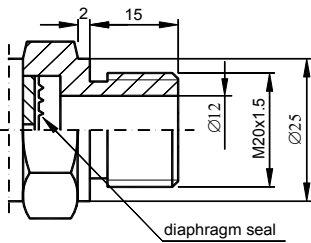

Fig.7a. P-type connector with M20x1.5 thread

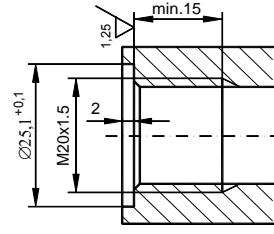

Fig.7b. Socket for P-type connector

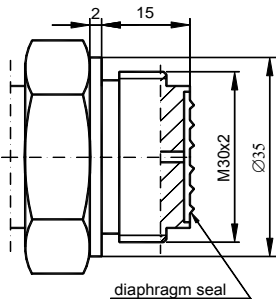

Fig.8a. CM30x2-type connector with flush diaphragm with M30x2 thread,

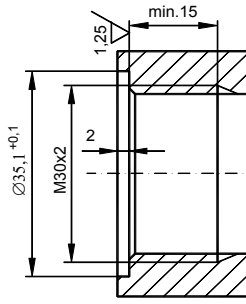

Fig.8b. Socket for CM30x2-type connector.

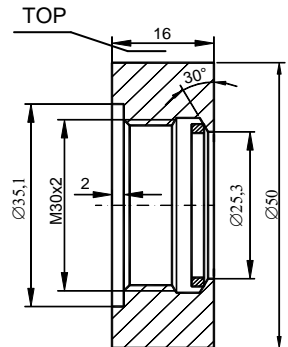

Fig.8c. Socket for CM30x2-type connector Sealing: teflon

Order code Socket CM30x2



The ring in Fig. 8c has to be welded in place with the word TOP upwards.

Fig. 6. M-type connector with M20x1.5 thread.

Fig. 7. P-type connector with M20x1.5 thread.

Fig. 8. CM30x2-type connector with flush diaphragm with M30x2 thread.



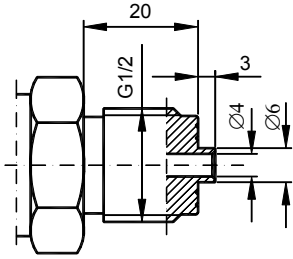

Fig.9a. G1/2 -type connector with G1/2" thread,

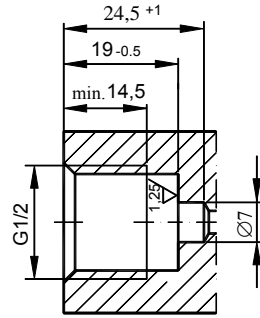

Fig.9b. Socket for G1/2-type connector.

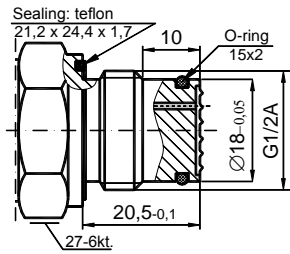

Fig.9c. CG1/2 -type connector with flush diaphragm with G1/2" thread,

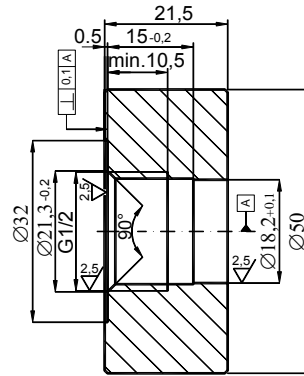

Fig.9d. Socket for CG1/2 - type connector  
**Order code Socket CG1/2**

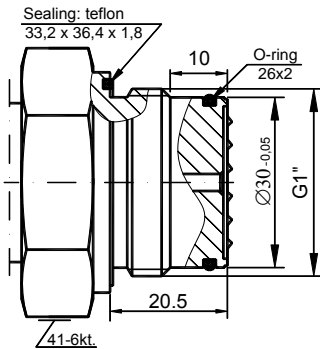

Fig.9e. CG1-type connector with flush diaphragm with G1" thread,

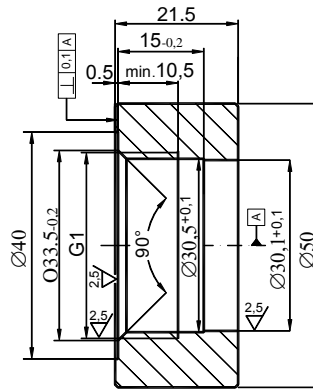

Fig.9f. Socket for CG1 - type connector  
**Order code Socket CG1**

**Fig. 9. Process connections G1/2" and G1".**

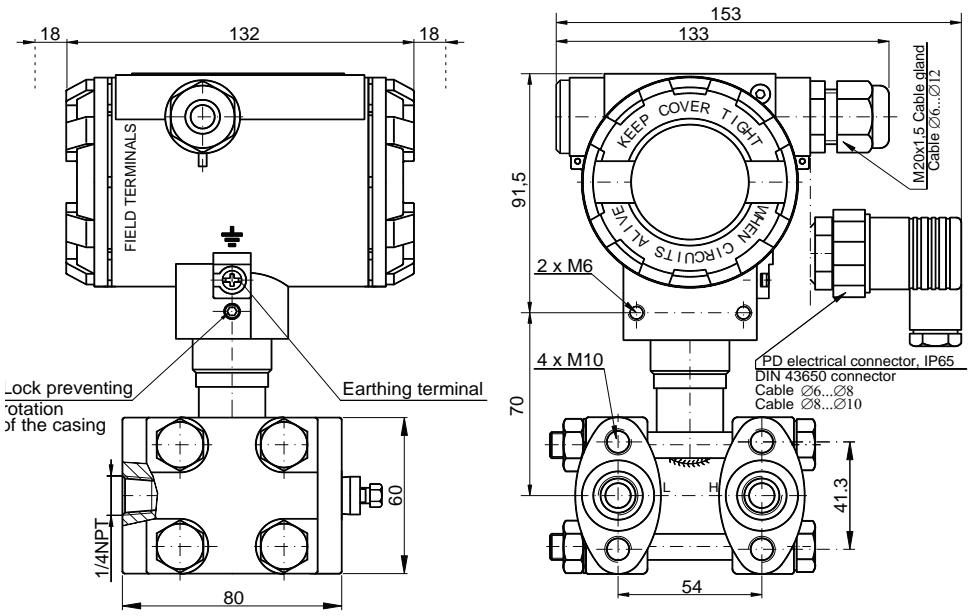

Fig. 10. APR-2000ALW differential pressure transmitter with C type vented covers.

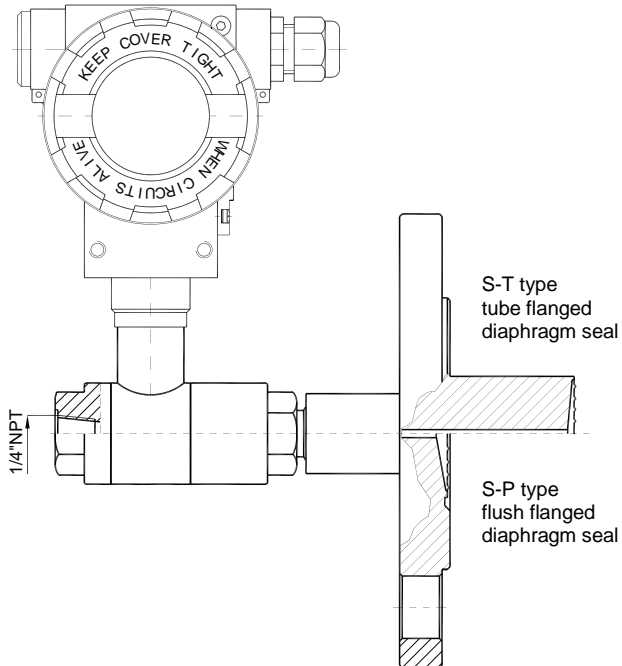
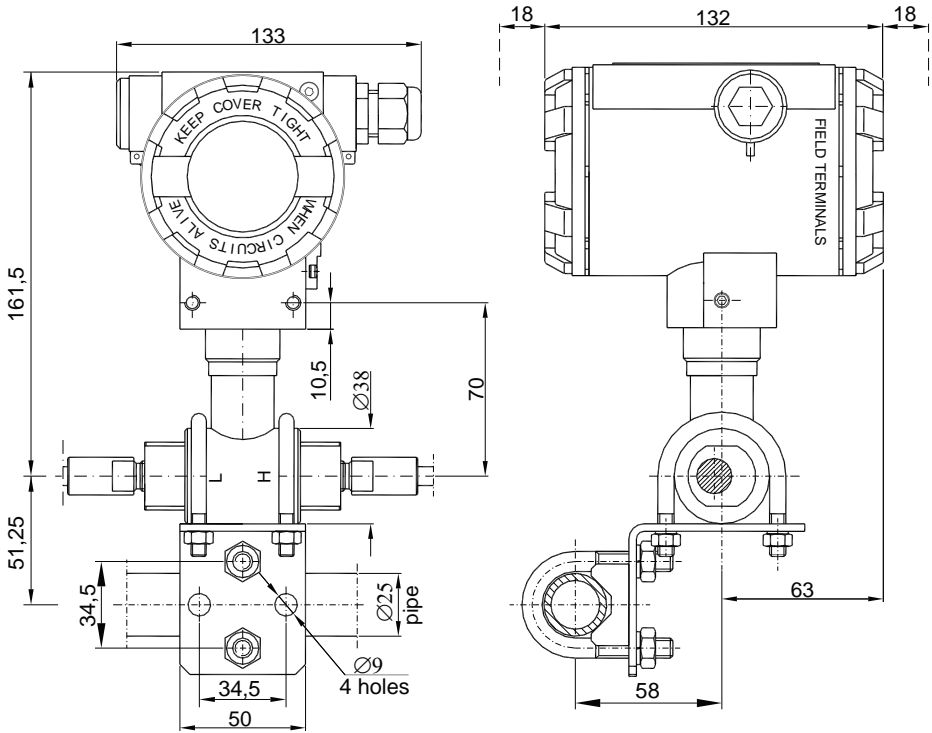

Fig. 11. APR-2000ALW differential pressure transmitter with a single direct diaphragm seal (example).



Assembly Kit ("Mounting bracket  $\varnothing 25$ " made by APLISENS) for fitting differential pressure transmitters with P-type connector on a  $\varnothing 25$  pipe see catalogue cards "Fitting accessories".

**Fig. 12.** Example: how to install the APR-2200ALW transmitters with remote diaphragm.

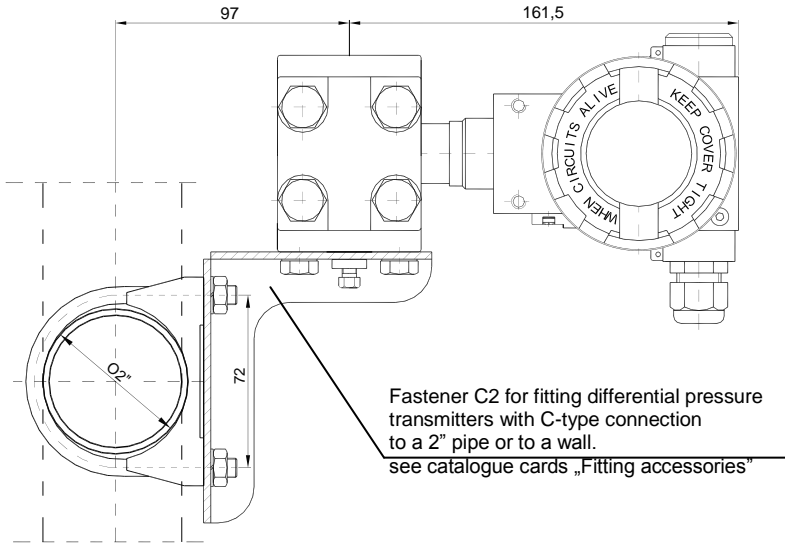

Fig. 13. Example: how to install the APR-2000ALW transmitter on a vertical or horizontal pipe.

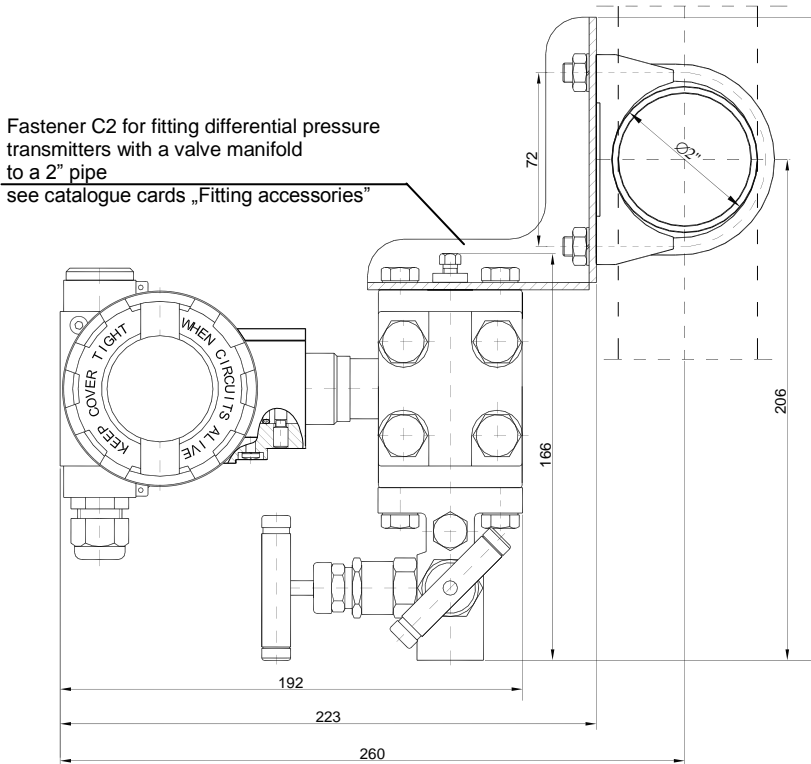
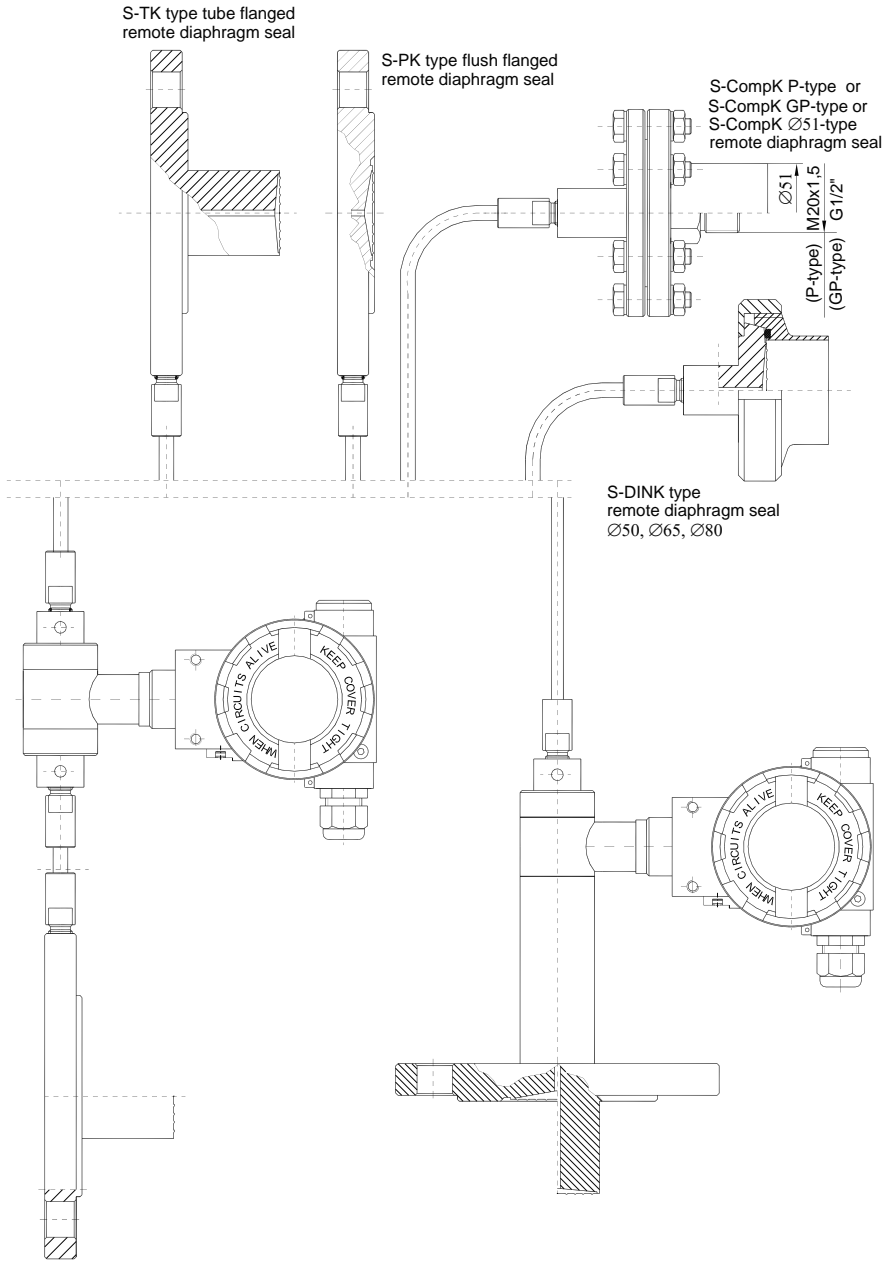

Fig. 14. Example: how to install the APR-2000ALW transmitter with a valve manifold to a 2" pipe.



**Fig. 15.** APR-2200ALW differential pressure transmitter with two remote diaphragm seals (examples).

**Fig. 16.** APR-2200ALW differential pressure transmitter with direct and remote diaphragm seal (examples).

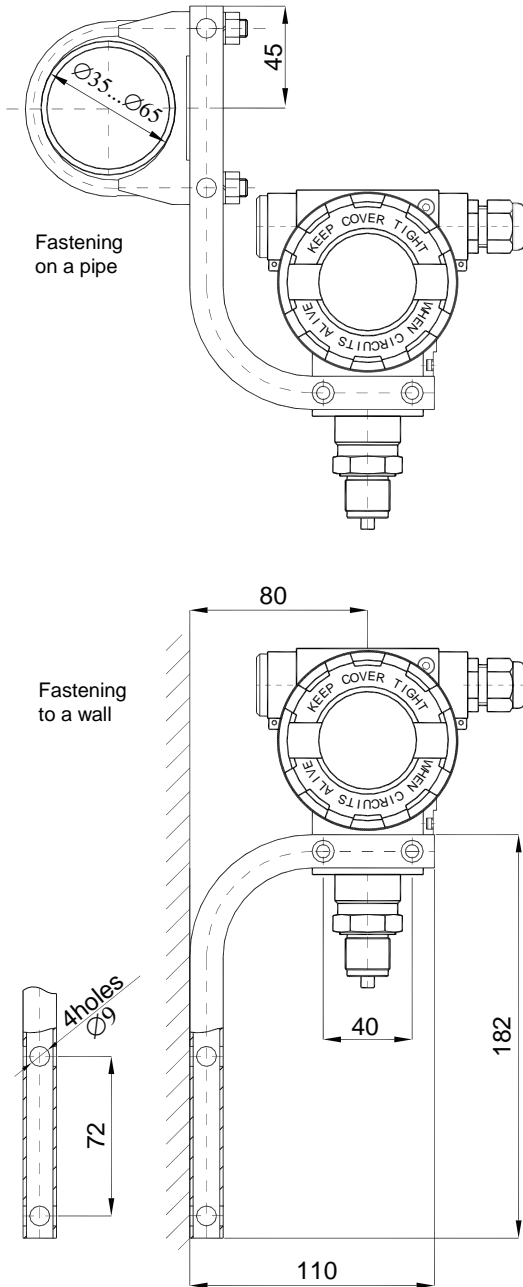
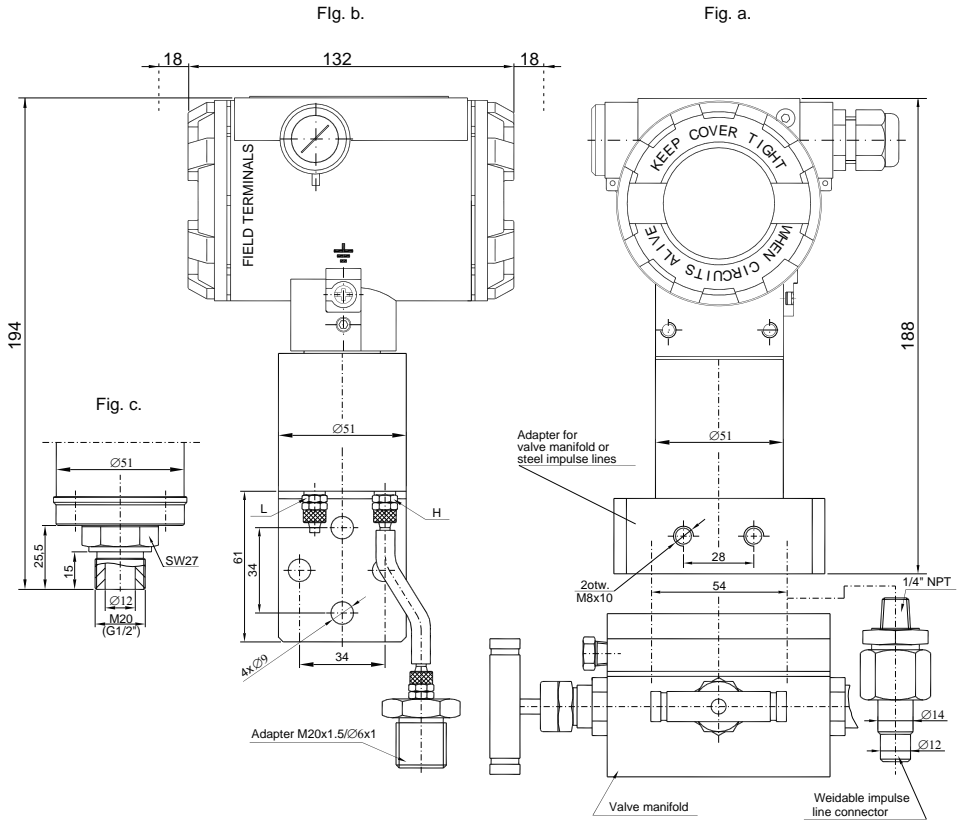
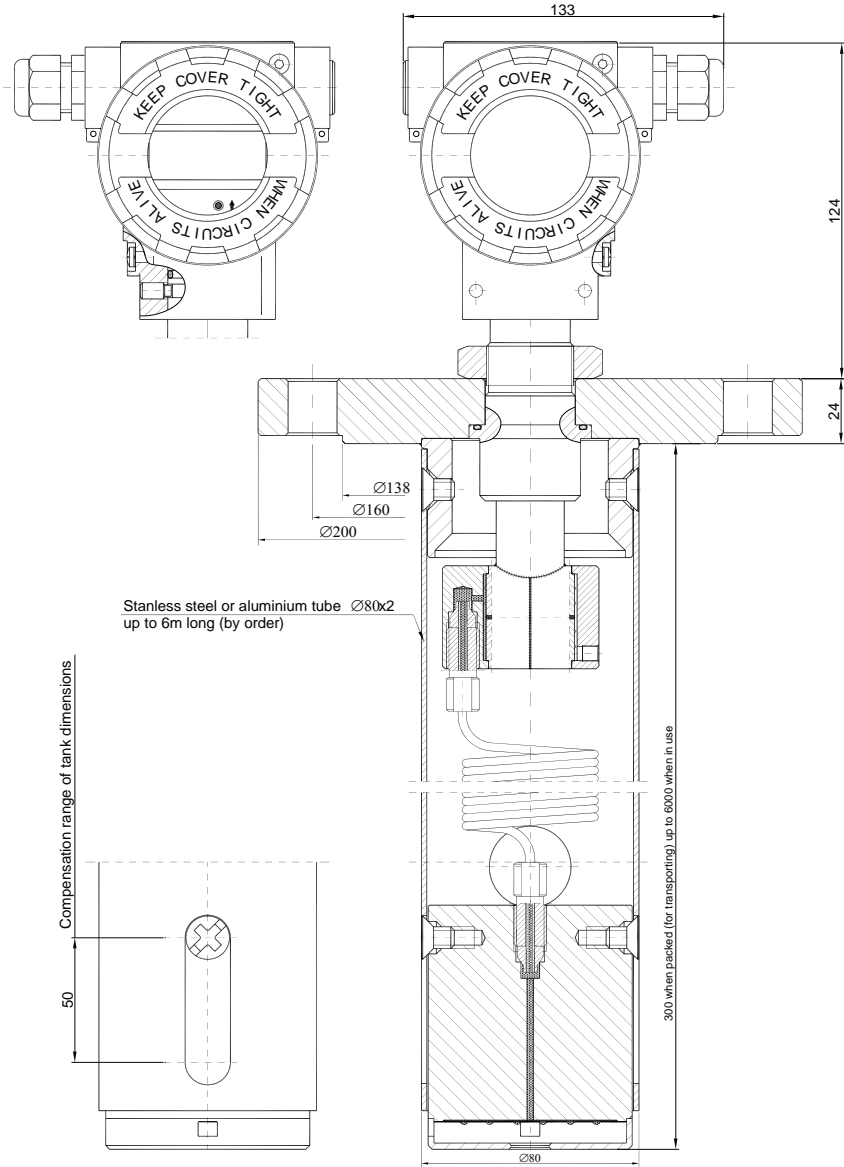

Fig. 17. Example: how to install the APC..., APR... transmitter.



**Fig. 18.** APR-2000GALW smart differential pressure transmitter for low ranges.

- a) APR-2000GALW transmitter – industrial version with C type process connector to mount together with a valve manifold or weldable impulse line connectors.
- b) APR-2000GALW transmitter – economical version with PCV type process connector.
- c) APR-2000GALW transmitter – with GP or P type process connector (G1/2" or M20x1,5 thread).



**Fig. 19.** APR-2000YALW smart level probe for pressure tanks.



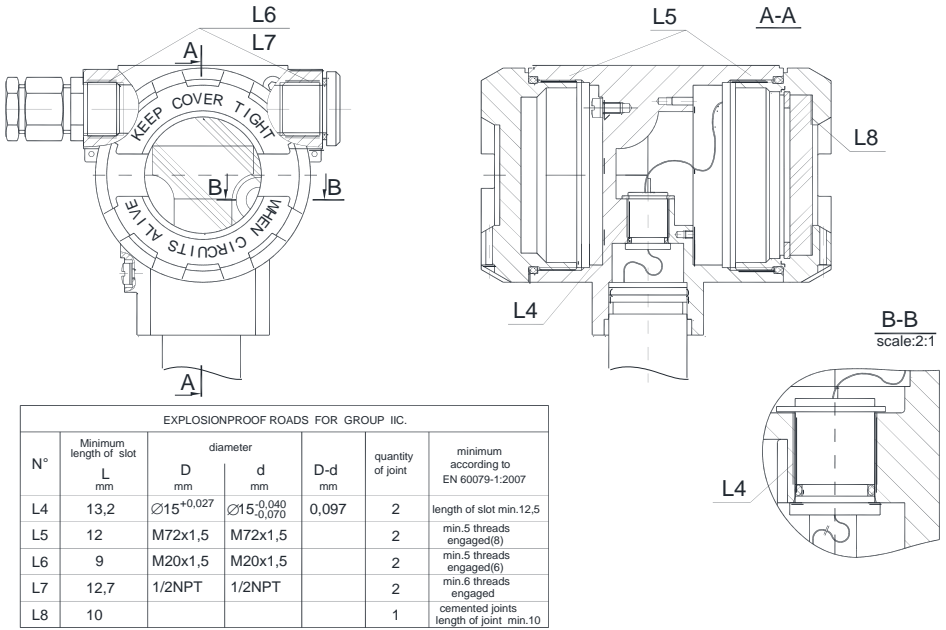

Fig. 20. The explosion - proof joints of APC..., APR... transmitters.

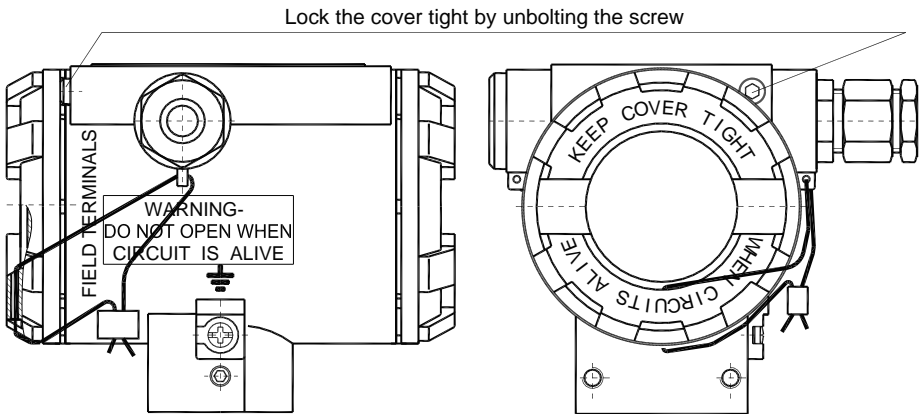

Fig. 21. How to lead the casing of APC..., APR... transmitters.

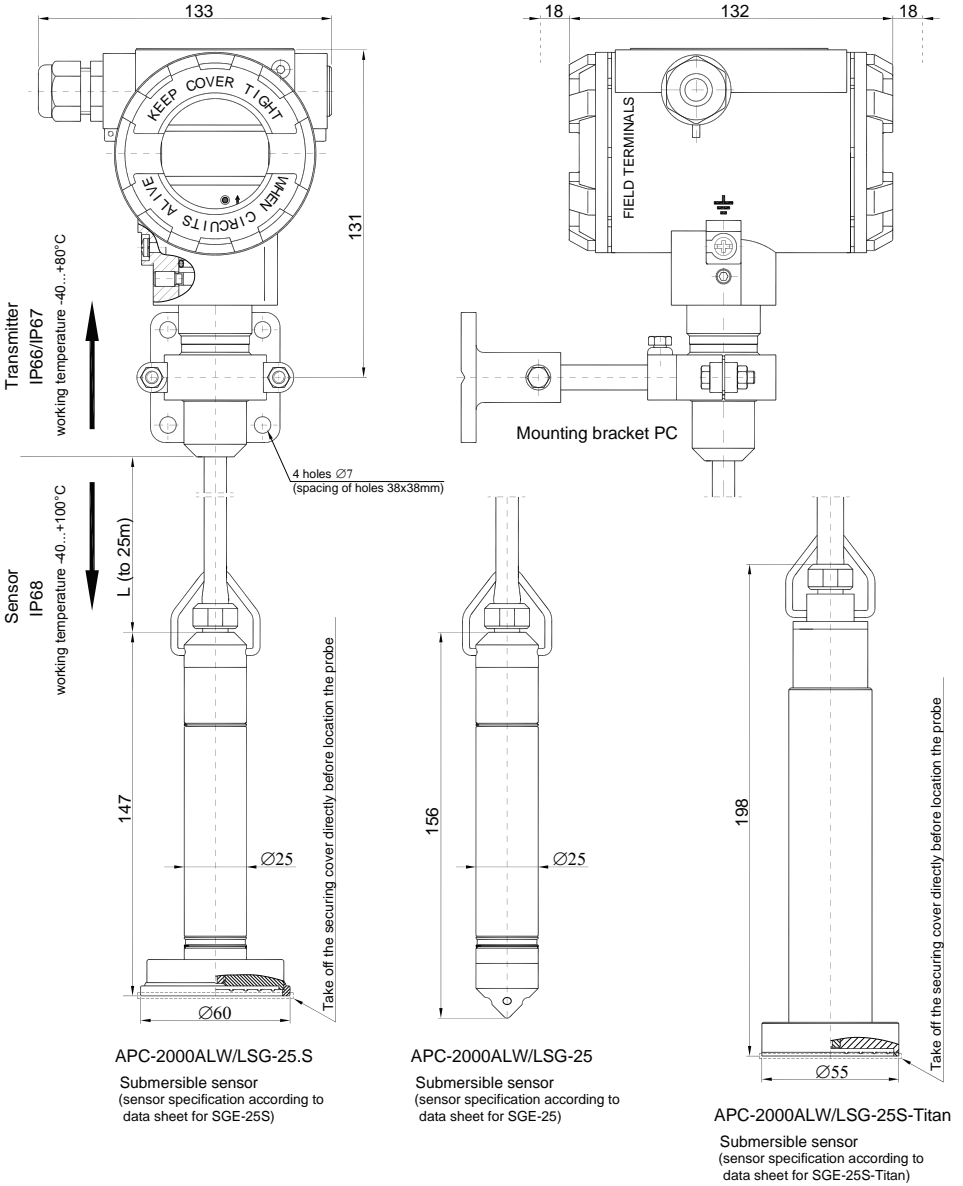
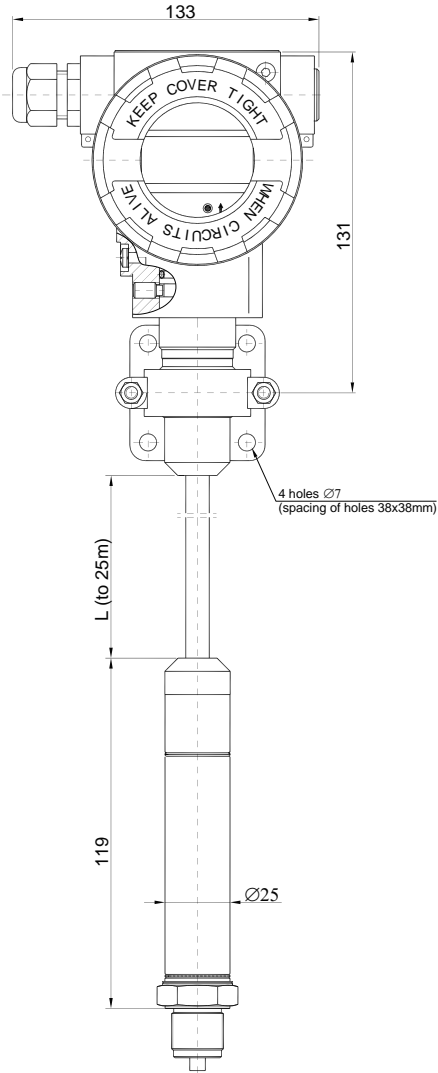
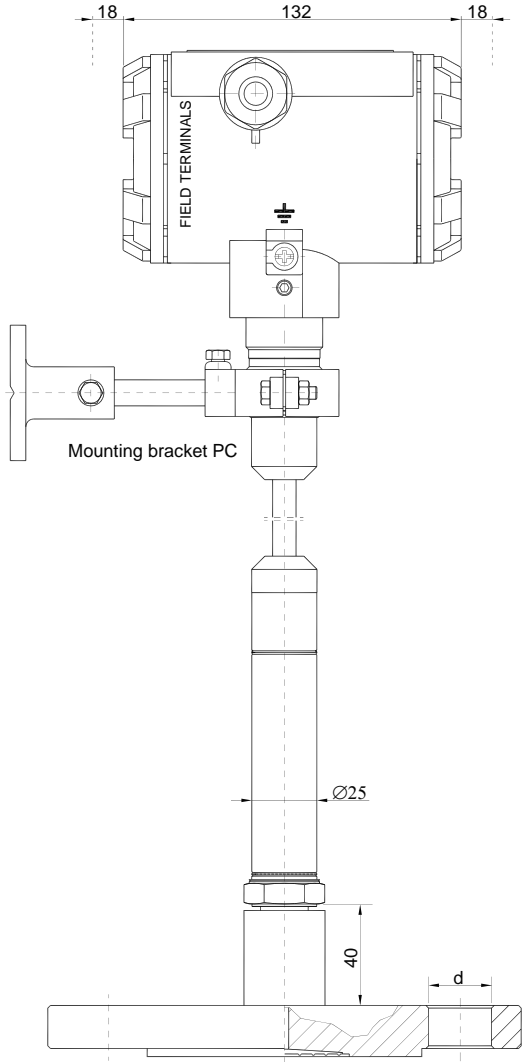

Fig. 22. APC-2000ALW/LSG... smart level transmitters.



APC-2000ALW/LM  
Transmitter with M type sensor



APC-2000ALW/LSP  
Transmitter with SP type diaphragm seal

Fig. 23. APC-2000ALW/LM & APC-2000ALW/LSP smart pressure or level transmitters.

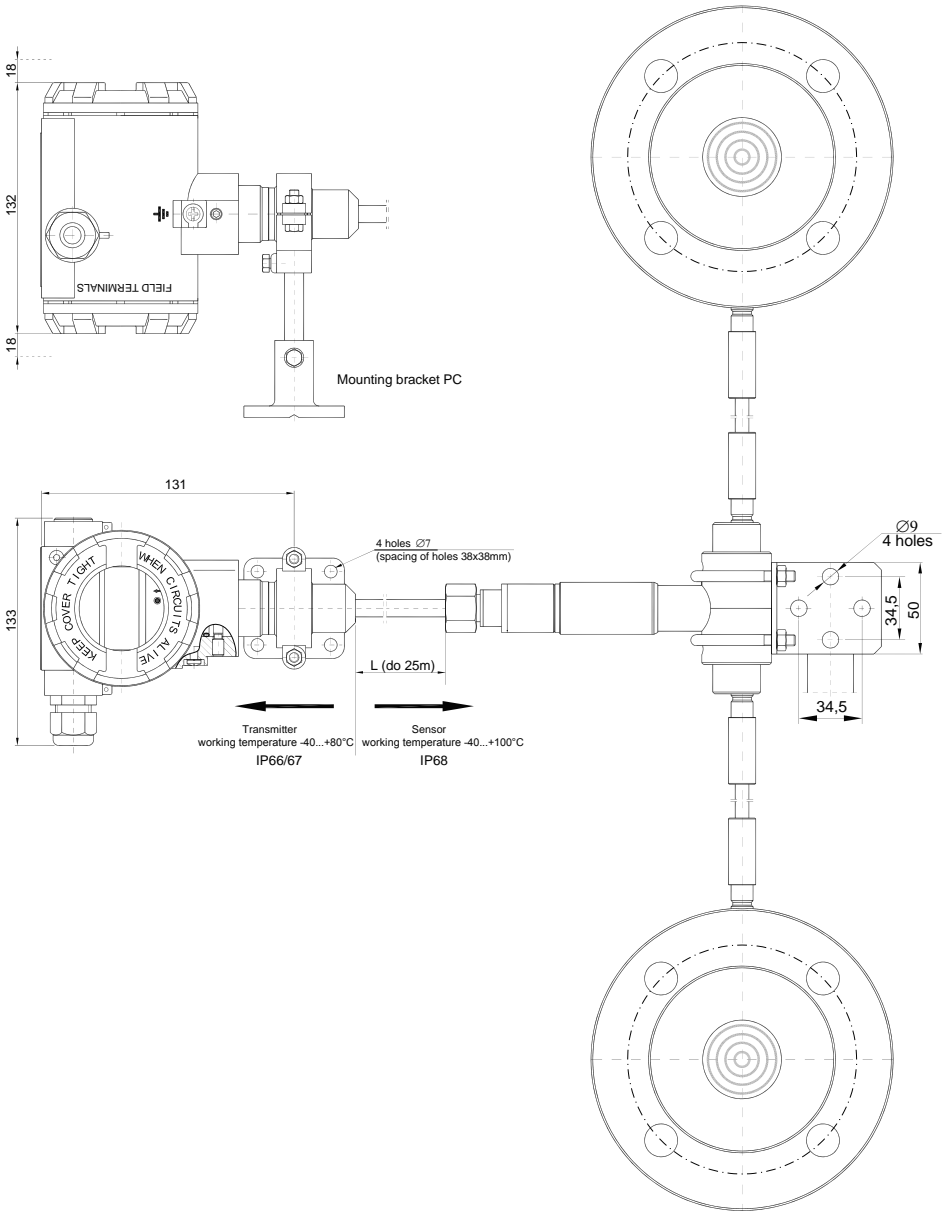

**Fig. 24.** An example of the differential pressure transmitter APR-2200ALW/L.

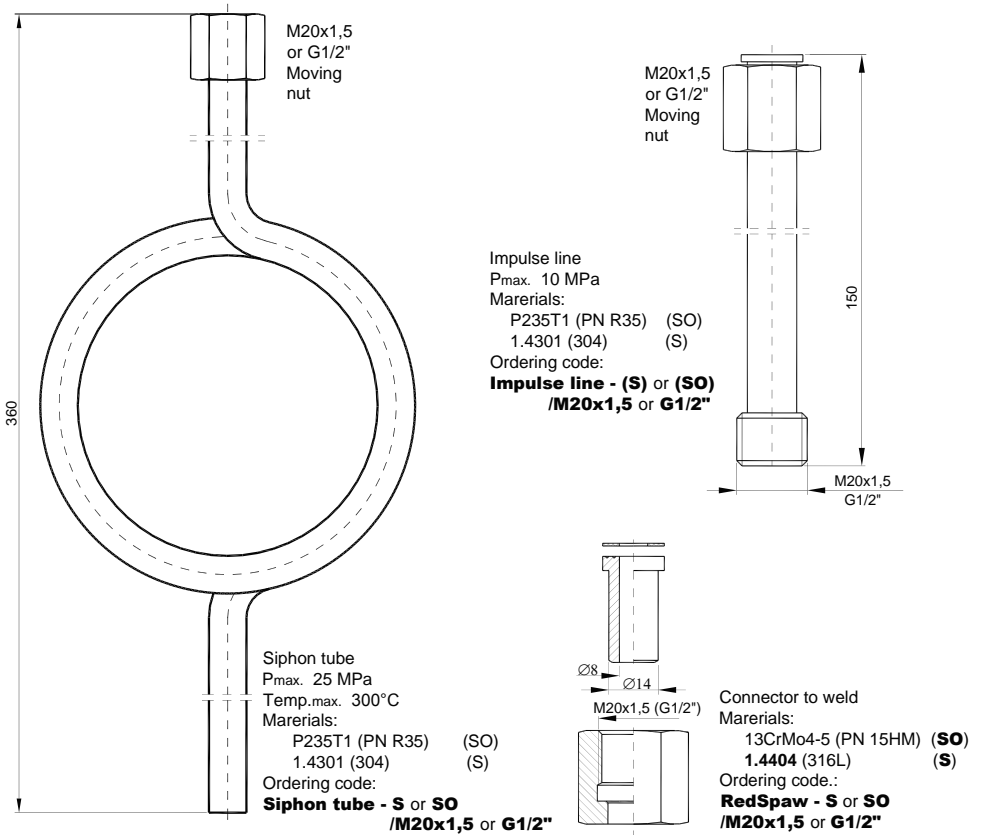

Fig. 25. Additional equipment for fitting of pressure transmitters.





